

NEC

MODEL PG-2740

Multisync COLOR DATA MONITOR
SERVICE MANUAL

PART No. 399910808

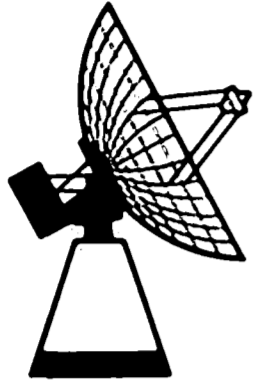

Better Service
Better Reputation
Better Profit

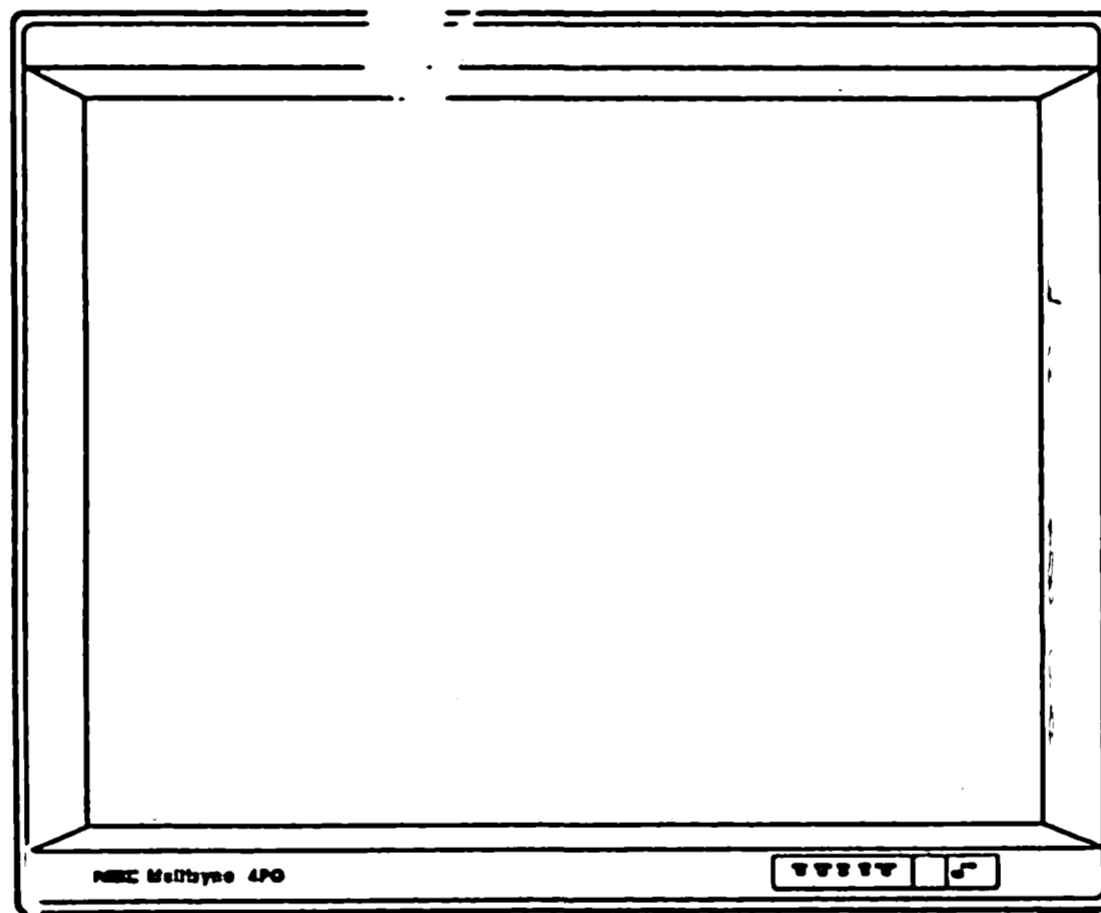

SPECIFICATIONS

SAFETY CAUTION:

Before servicing this chassis, it is important that the service technician read and follow the "Safety Precautions" and "Product Safety Notice" in this Service Manual.

* For continued X-radiation protection, replace picture tube with original type or NEC approved equivalent type.

WARNING:

SHOCK HAZARD - Use an isolation transformer when servicing.

NEC Corporation

TOKYO, JAPAN

CONTENTS

SAFETY PRECAUTIONS	2
PRECAUTIONS DE SECURITE	4
SPECIFICATIONS	6
LOCATION AND FUNCTIONS OF CONTROLS	8
Front Panel.....	8
Terminal Board (Left)	9
Terminal Board (Right)	11
Remote Control Unit.....	13
ADJUSTMENTS PROCEDURES	15
1. Power Supply Check.....	16
2. Horizontal Oscillation Adjustment	16
2-1 SUB PWB Horizontal Oscillation Adjustment	16
2-2 RGB PWB Horizontal Oscillation Adjustment	16
3. Vertical Oscillation Adjustment	16
3-1 DEF SUB PWB Vertical Oscillation Adjustment	16
3-2 RGB PWB Vertical Oscillation Adjustment	16
4. High Voltage Adjustment	17
4-1 DEF SUB and DEF/HV High Voltage Adjustments	17
4-2 DEF SUB and DEF/HV High Voltage Protector Adjustment	17
5. Video Chroma Circuit Adjustment	17
5-1 PAL Comb Filter Adjustment	17
5-2 Sub-Bright and Sub-Contrast Adjustments	17
5-3 PAL Matrix Adjustment	18
5-4 Auto Phase Control Adjustment.....	18
6. Horizontal Width Adjustment.....	19
7. Vertical Linearity Adjustment	19
8. Vertical Height Adjustment.....	19
9. Side Pin Cushion Adjustment	19
10. Kystone Adjustment	19
11. Image Tilt Correction	19
12. White Balance Procedure	20
13. Audio Circuit Adjustment.....	21
14. Rester D/A Control Setting.....	21
15. Video D/A Control Setting	23
16. Dynamic Focus Waveform Adjustment	24
17. Focus Adjustment	24
18. High-Voltage Protector Circuit Operation Verification	24
CABINET DRAWING	25
PACKAGING	28
CONNECTION DIAGRAM	34
BLOCK DIAGRAM	35

SCHEMATIC DIAGRAMS	39
RGB I/O PWB 1/2 (PWC-3835)	39
RGB I/O PWB 2/2 (PWC-3835)	40
RGB PWB 1/2 (PWC-3836)	41
RGB PWB 2/2 (PWC-3836)	42
VIDEO I/O PWB (PWC-3837)	43
VIDEO PWB 1/2 (PWC-3838)	44
VIDEO PWB 2/2 (PWC-3838)	45
V-CRT PWB (PWC-3834)	46
μ COM/V PWB 1/3 (PWC-3839)	47
μ COM/V PWB 2/3 (PWC-3839)	48
μ COM/V PWB 3/3 (PWC-3839)	49
DEF/HV PWB 1/2 (PWC-3846)	50
DEF/HV PWB 2/2 (PWC-3846)	51
DEF SUB PWB 1/2 (PWC-3856A)	52
DEF SUB PWB 2/2 (PWC-3856A)	53
MAIN POWER SUPPLY PWB (PWC-3815A)	54
SUB POWER SUPPLY PWB (PWC-3851B, C, D)	55
H OUT PWB (PWC-3856B)	56
SW-LED PWB (PWC-3838B)	57

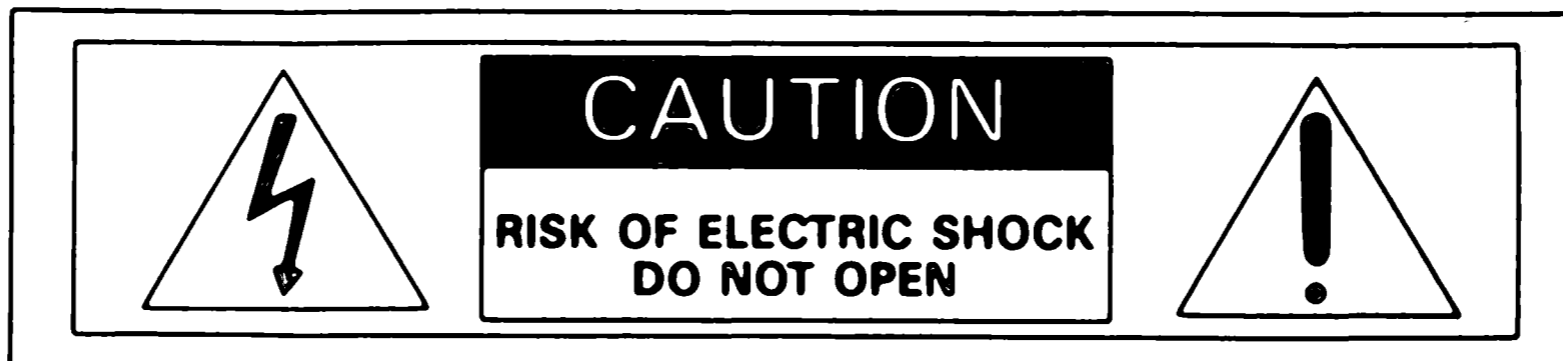

CAUTION: TO REDUCE THE RISK OF ELECTRIC SHOCK, DO NOT REMOVE COVER (OR BACK). NO USER-SERVICEABLE PARTS INSIDE. REFER SERVICING TO QUALIFIED SERVICE PERSONNEL.

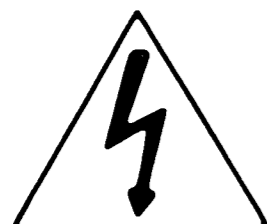

This symbol warns the user that un-insulated voltage within the unit may have sufficient magnitude to cause electric shock. Therefore, it is dangerous to make any kind of contact with any part inside of this unit.



This symbol alerts the user that important literature concerning the operation and maintenance of this unit has been included. Therefore, it should be read carefully in order to avoid any problems.



ATTENTION: POUR EVITER LES RISQUES D'ELECTROCUTION, NE PAS ENLEVER LE COUVERCLE (OU LE DOS). AUCUN DES ELEMENTS INTERNES NE DOIT ETRE REPARÉ PAR L'UTILISATEUR. NE CONFIER L'ENTRETIEN QU'À UN PERSONNEL QUALIFIÉ.

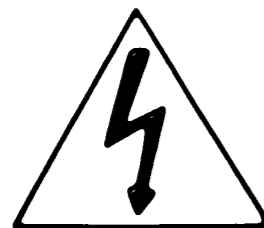

L'éclair fléché dans un triangle équilatéral est destiné à avertir l'utilisateur de la présence, dans l'appareil, d'une zone non-isolée soumise à une haute tension dont l'intensité est suffisante pour constituer un risque d'électrocution.



Le point d'exclamation dans un triangle équilatéral est destiné à attirer l'attention de l'utilisateur sur la présence d'informations de fonctionnement et d'entretien importantes dans la brochure accompagnant l'appareil.

SAFETY PRECAUTIONS

1. Before returning an instrument to the customer, always make a safety check of the entire instrument, including, but not limited to, the following items:

a. Be sure that no built-in protective devices are defective and/or have been defeated during servicing. (1) Protective shields are provided on this chassis to protect both the technician and the customer. Correctly replace all missing protective shields, including any removed for servicing convenience. (2) When reinstalling the chassis and/or other assembly in the cabinet, be sure to put back in place all protective devices, including but not limited to, nonmetallic control knobs, insulating fishpapers, adjustment and compartment covers/shields, and isolation resistor/capacitor networks **Do not operate this instrument or permit it to be operated without all protective devices correctly installed and functioning.**

b. Be sure that there are no cabinet openings through which an adult or child might be able to insert their fingers and contact a hazardous voltage. Such openings include, but are limited to, (1) spacing between the picture tube and the cabinet mask, (2) excessively wide cabinet ventilation slots, and (3) an improperly fitted and/or incorrectly secured cabinet back cover.

c. **Leakage Current Hot Check** - With the instrument completely reassembled, plug the AC line cord directly into a 120V AC outlet. (Do not use an isolation transformer during this test.) Use a leakage current tester or a metering system that complies with American National Standards Institute (ANSI) *C101.1 Leakage Current for Appliances* and Underwriters Laboratories UL 1950 (5.2). With the instrument AC switch first in the ON position and then in the OFF position, measure from a known earth ground (metal waterpipe, conduit, etc) to all exposed metal parts of the instrument (antennas, handle bracket, metal cabinet, screwheads, metallic overlays, control shafts, etc.), especially any exposed metal parts that offer an electrical return path to the chassis. Any current measured must not exceed 3.5 milliamp. Reverse the instrument power cord plug in the outlet and repeat test. **ANY MEASUREMENTS NOT WITHIN THE LIMITS SPECIFIED HEREIN INDICATE A POTENTIAL SHOCK HAZARD THAT MUST BE ELIMINATED BEFORE RETURNING THE INSTRUMENT TO THE CUSTOMER.**

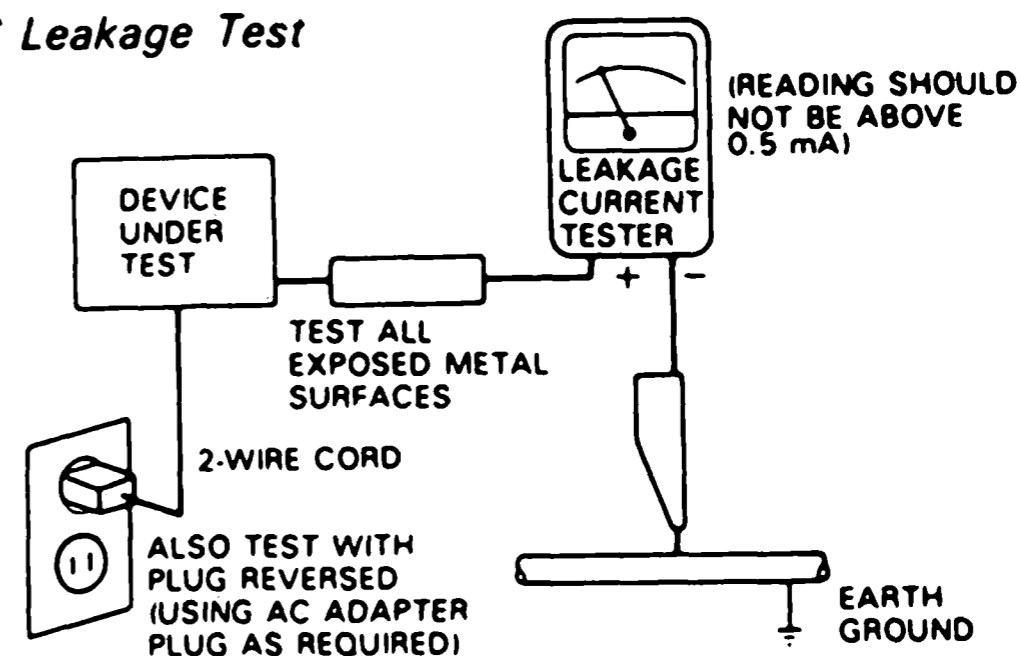

AC Leakage Test



d. **X-Radiation and High-Voltage Limits** - Because the picture tube is the primary potential source of X-radiation in solid-state Equipment, it is specially constructed to prohibit X-radiation emissions. For continued X-radiation protection, the replacement picture tube must be the same type as the original. Also, because the picture tube shields and mounting hardware perform an X-radiation protection function, they must be correctly in place. High voltage must be measured each time servicing is performed that involves B+, horizontal deflection or high voltage. Correct operation of the X-radiation protection circuits also must be reconfirmed each time they are serviced. (X-radiation protection circuits also may be called "Horizontal disable" or "Hold-down.") Read and apply the high-voltage limits and, if the chassis is so equipped, the X-radiation protection circuit specifications given on instrument labels and in the *Product Safety & X-radiation Warning* note on the service data chassis schematic.

High voltage is maintained within specified limits by close-tolerance safety-related components/adjustments in the high-voltage circuit. If high voltage exceeds specified limits, check each component specified on the chassis schematic and take corrective action. (Refer to "SERVICE ADJUSTMENT")

2. Read and comply with all caution and safety-related notes on or inside the receiver cabinet, on the receiver chassis, or on the picture tube.

3. **Design Alteration Warning** - Do *not* alter or add to the mechanical or electrical design of this Equipment. Design alterations and additions, including, but not limited to, circuit modifications and the addition of items such as auxiliary audio and/or video output connections, might alter the safety characteristics of this receiver and create a hazard to the user. Any design alterations or additions will void the manufacturer's warranty and will make you, the servicer, responsible for personal injury or property damage resulting therefrom.
4. **Picture Tube Implosion Protection Warning** - The picture tube in this receiver employs integral implosion protection. For continued implosion protection, replace the picture tube only with one of the same type number. Do *not* remove, install, or otherwise handle the picture tube in any manner without first putting on shatterproof goggles equipped with side shields. People not so equipped must be kept safely away while picture tubes are handled. Keep the picture tube away from your body. Do not handle the picture tube by its neck. Some "in-line" picture tubes are equipped with a permanently attached deflection yoke; because of potential hazard, do *not* try to remove such "permanently attached" yokes from the picture tube.
5. **Hot Chassis Warning** - a. Some Equipment chassis are electrically connected directly to one conductor of the AC power cord and may be safely serviced without an isolation transformer only if the AC power plug is inserted so that the chassis is connected to the *ground* side of the AC power source. To confirm that the AC power plug is inserted correctly, with an AC voltmeter measure between the chassis and a known earth ground. If a voltage reading in excess of 1.0V is obtained, remove and reinsert the AC power plug in the opposite polarity and again measure the voltage potential between the chassis and a known earth ground. b. Some Equipment chassis normally have 85V AC (RMS), between chassis and earth ground regardless of the AC plug polarity. These chassis can be safely serviced only with an isolation transformer inserted in the power line between the receiver and the AC power source, for both personnel and test equipment protection. c. Some Equipment chassis have a secondary ground system in addition to the main chassis ground. This secondary ground system is not isolated from the AC power line. The two ground systems are electrically separated by insulating material that must not be defeated or altered.
6. Observe original lead dress. Take extra care to assure correct lead dress in the following areas: a. near sharp edges, b. near thermally hot parts - be sure that leads and components do not touch thermally hot parts, c. the AC supply, d. high voltage, and e. antenna wiring. Always inspect in all areas for pinched, out-of-place, or frayed wiring. Do not change spacing between components, and between components and the printed-circuit board. Check AC power cord for damage.
7. Components, parts, and/or wiring that appear to have overheated or are otherwise damaged should be replaced with components, parts, or wiring that meet original specifications. Additionally, determine the cause of overheating and/or damage and, if necessary, take corrective action to remove any potential safety hazard.
8. **PRODUCT SAFETY NOTICE** - Many TV electrical and mechanical parts have special safety-related characteristics some of which are often not evident from visual inspection, nor can the protection they give necessarily be obtained by replacing them with components rated for higher voltage, wattage etc. Parts that have special safety characteristics are identified in this service data by shading with a  mark on schematics and by shading or a  mark in the parts list. Use of a substitute replacement part that does not have the same safety characteristics as the recommended replacement part in this service data parts list might create shock, fire, and/or other hazards.

PRECAUTIONS DE SECURITE

1. Avant de remettre un appareil à un client, faire toujours d'abord un examen de sécurité de l'appareil en entier comprenant, mais ne s'y limitant pas les points cités ci-dessous:

a. Vérifier qu'aucun des dispositifs de protection ne soit défectueux ou n'ait été endommagé pendant les travaux.

(1) Les volets protecteurs sur ce châssis ont été montés pour protéger aussi bien le technicien que le client. Remplacer correctement tous les volets protecteurs manquants, aussi bien que ceux qui ont pu être enlevés pour la commodité des travaux.
(2) Quand vous remettez le châssis ou d'autres assemblages ensemble dans le coffret, vérifier qu'ont été remis à leur place tous les dispositifs de protection, comprenant mais ne s'y limitant point, les boutons de contrôle non-métalliques, les feuilles d'isolation, les couverture/volets de l'ajustement et du compartiment, et l'isolation des réseaux résistance/condensateur. **Ne pas travailler sur cet appareil ni permettre qu'y soit effectué un travail sans que tous les dispositifs de protection n'y soient correctement installés fonctionnants.**

b. Bien vérifier qu'il n'y ait aucune ouverture sur le coffret qui ne puisse permettre à un adulte ou à un enfant d'y faire pénétrer ses doigts et attraper une décharge électrique.

De telles ouvertures comprendraient sans pour autant s'y limiter (1) l'espace entre le tube à images et le coffret de l'appareil, (2) les espaces excessivement ouverts pour la ventilation et (3) la couverture arrière du coffret improprement fixée ou incorrectement protégée.

c. **Vérification de courant de fuite**

L'appareil ayant été complètement réassemblé, brancher-le à une prise de courant de 120V. (Ne pas se servir d'un transformateur d'isolation pendant ce test). Se servir d'un vérificateur de courant d'excitation ou d'un système de mesure conforme aux normes ANSI (AMERICAN National Standards Institute) C101.1 Leakage Current for Appliances et U.L (Underwriters Laboratories) 1950 (5.2). Le bouton de l'appareil en position "Marche" et ensuite en position "Arrêt", mesurer à partir d'une prise de terre (métallique tuyauterie, conduite, etc...) à toutes les pièces métalliques de l'appareil exposées (antennes, poignet métalliques, coffret métallique, tête de vis, surfaces métalliques, traits de contrôle, etc.) surtout à toutes les pièces métalliques exposées qui peuvent reconduire le courant au châssis. En aucun cas, la mesure du courant ne doit dépasser 3.5 milliamp. Inverser la fiche de courant de

l'appareil dans la prise et répéter le test. **Tout mesurage ne s'arrêtant pas aux limites spécifiées ici comporte un risque de décharge électrique dangereux, qui doit être éliminé, avant que l'appareil ne soit remis au client.**

EXAMEN DE COURANT D'EXCITATION

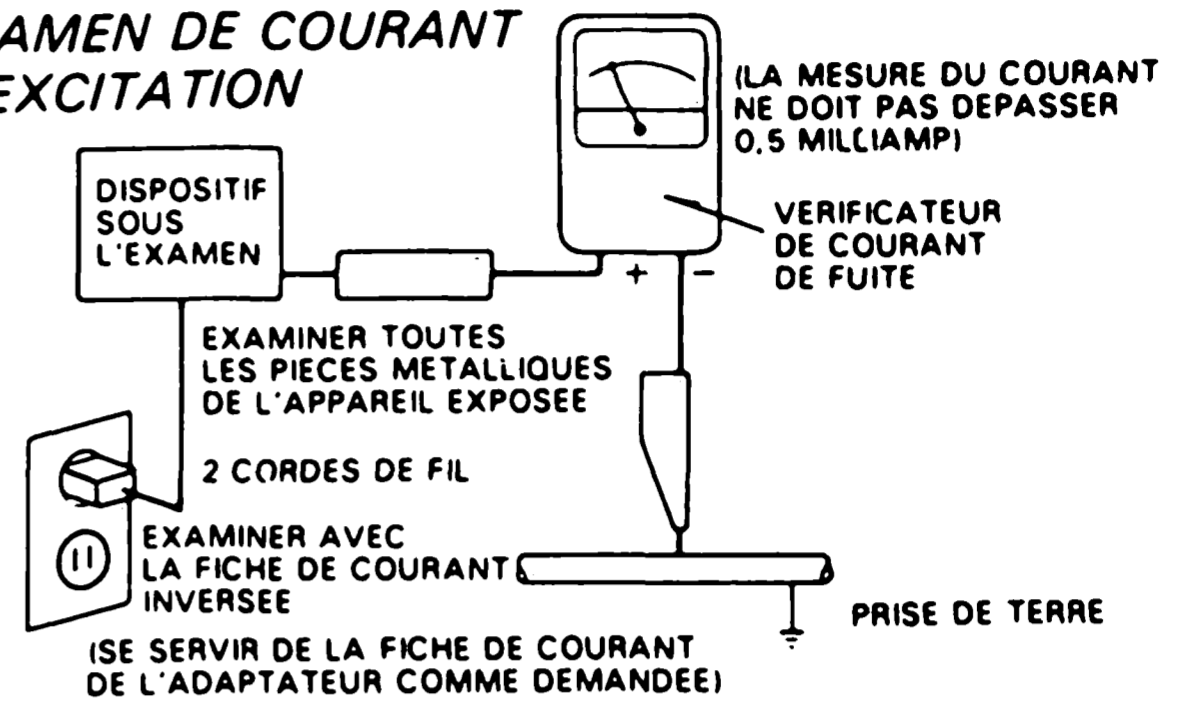

d. **Limitation des rayons-X et de la haute-tension**

Comme le tube à images est la source potentielle première des émissions des rayons-X dans les téléviseurs en état solide, il est particulièrement conçu pour ne pas laisser échapper les émissions des rayons-X.

Pour une protection continue contre les émissions des rayons-X, le tube à images remplacé doit être du même type que l'original. Et aussi, parce que le couvert du tube à images et le hardware de montage ont une fonction de protection contre les rayons-X, ils doivent être correctement mis en place. La haute tension doit être mesurée chaque fois que l'entretien s'occupe du B+, de la déviation horizontale ou de la haute tension. Il faudra aussi s'assurer du bon fonctionnement des circuits de protections anti-Rayons-X chaque fois qu'ils seront amenés en entretien. (les circuits de protections anti-Rayons-X pourront aussi bien être appelés, "horizontal disable" ou "hold-down".) Lire et appliquer les limitations de haute tension, et si le châssis en est équipé, les spécifications de protections contre les rayons-X données dans les notices d'appareil, ou bien dans le texte "Product Safety & X-radiation Warning" sur le schéma d'entretien du châssis.

La haute tension est maintenue dans les limites spécifiées, par la capacité de tolérance et de sécurité des composants et des ajustements dans le circuit de haute tension. Si la haute tension dépasse les limites spécifiées, contrôler et réparer chaque composant relatif sur le schéma du châssis. (Voir "SERVICE ADJUSTMENTS")

2. Lire et respecter toutes les mises en garde et notes de sécurité à l'intérieur ou à l'extérieur du coffret du récepteur, sur le châssis du récepteur ou sur le tube à images.

3. Mise en garde contre la modification du dessin

Ne pas modifier ni ajouter à la pièce mécanique ou électrique de l'équipement. Des modifications ou additions, comportant, mais ne s'y limitant pas, des modifications des circuits et l'addition d'éléments tels que des auxiliaires audio et/ou des branchements pour la prise de vidéo, pourrait éprouver la sécurité de ce récepteur et créer un risque pour l'utilisateur. Tout changement ou addition accomplie annulera la garantie du fabricant et va rendre votre service d'entretien, responsable des dommages corporels ou de biens en résultant.

4. Mise en garde contre l'implosion du tube à images

Le tube à images dans ce récepteur marche avec une protection contre une implosion totale. Pour une protection continue contre l'implosion ne remplacer le tube à images que par un autre type du même numéro. Ne pas enlever, installer, ou tenir, ou tenir le tube à images quelque soit le prétexte sans au préalable porter des lunettes de protections comportant des couverts latéraux. L'on n'étant pas ainsi équipé doit être tenu éloigné pendant qu'est manipulé le tube à images. Maintenir le tube à images éloigné de votre corps. Ne pas manipuler le tube à images par son goulot. Certains tubes à images "in-line" sont équipés avec des Jougs de déviations rattachés en permanence, à cause d'un danger potentiel, ne jamais essayer d'enlever ces "Jougs" rattachés en permanence au tube à images.

5. Mise en garde contre le châssis sous tension

a. Certains châssis d'équipement sont électriquement reliés à un conducteur du fil de courant et ainsi peuvent ne comporter aucun risque sans un transformateur d'isolation seulement si la prise de courant est branchée, de manière que le châssis est relié à la prise de terre de la source de courant. Pour s'assurer que la prise de courant est correctement insérée, relever les mesures avec un voltmètre de courant entre le châssis et un point de prise de terre bien connu. Si le voltage indiqué est supérieur à 1,0V, débrancher et reinsérer la prise de courant dans la polarité contraire et une fois de plus remesurer le voltage potentiel entre le châssis et la prise de terre.

b. Certains châssis d'équipement ont habituellement 85V (RMS) entre le châssis et la prise de terre, en fonction de la polarité de la prise de courant. Ces châssis peuvent ne comporter aucun risque seulement avec un transformateur d'isolation inséré dans la ligne de puissance située entre le récepteur et la source d'électricité, cela pour la protection aussi bien du personnel que du matériel de vérification.

c. Certains châssis d'équipement ont un système secondaire de masse en addition avec le système principal de masse du châssis. Ce système secondaire

de masse n'est pas isolé du courant électrique. Les deux systèmes sont électriquement séparés par du matériel d'isolation qu'on vérifiera bien qu'il ne soit ni altéré ni défectueux.

6. Vérifier la couverture originale en plomb. Accorder la plus grande attention à la couverture de plomb notamment aux endroits ci-dessous indiqués.

a. près des bords aigus

b. près des parties très chaudes

Vérifier que les composants et les plombs ne touchent pas les parties très chaudes telles que:

c. l'alimentation du courant

d. la haute tension



e. les fils de l'antenne

Pousser l'inspection, à tous les endroits, à la recherche des cordes pincées, déplacées ou effilochées. Ne pas changer l'écartement entre composants, et entre composants et le tableau de circuit imprimé. Vérifier que le fil de conduite électrique est en bon état.

7. Les composants, parts (pièces) et/ou fils qui ont été trouvés surchauffés devraient être remplacés avec les composants, pièces et fils s'y reliant avec d'autre qui ont les mêmes spécifications que les originales. De plus, rechercher la cause du surchauffement et/ou des dommages et si nécessaire, prendre les mesures propres pour prévenir tout risque potentiel.

8. Note sur la sûreté de l'appareil

Beaucoup de pièces de téléviseurs, qu'elles soient électriques ou mécaniques, ont des dispositions de sécurité qui ne sont pas toujours évidentes d'une simple inspection visuelle et la protection qu'elles donnent nécessairement ne pourront être pas obtenues par les remplaçants avec des composants aux voltages ou watts plus élevés.

Les pièces qui ont des caractéristiques particulières de sécurité sont identifiées avec un trait  marqué sur les schémas et sont ombragés ou comportent un trait  sur la liste des pièces. L'utilisation d'un produit substitutif qui n'aurait pas les mêmes caractéristiques comme il est recommandé dans ces données d'entretien pourrait provoquer une décharge électrique, un feu, et/ou d'autres dangers.

SPECIFICATIONS

Picture tube	27 Inch Visual size (Diagonal), Type A68KZN696X(T) 108 degree deflection Stripe tri pitch Ph=0.80-0.96mm, Pv=0.75mm Invar mask, Medium-short persistence phosphor Anti-static electricity coating Optical filter coating Dynamic focus
Display Colors	Analog Input: Unlimited colors
Synchronization Range	Horizontal: 15.5 KHz to 50 KHz (Automatically) Vertical: 40 Hz to 120 Hz (Automatically)
Resolution	RGB Horizontal : 800 lines / Vertical: 600 lines VIDEO Horizontal: 600 lines
Video Bandwidth	RGB: 40 MHz (When No.6 pin of DIP SW 1 set to OFF) VIDEO: 8 MHz
Display Area	RGB : 95% Scan (Typically), 100% Scan (Maximum) VIDEO: 7% Overscan
Retrace Time	Horizontal: 4.2 μ sec Vertical: 0.55 msec
Power Supply	AC 120 V, 60 Hz

Power Consumption	3.5 A (maximum)
Dimensions	645(W) x 530(H) x 520(D) mm / 25.39(W)X20.98(H)X20.39(D) inches
Weight	54kg / 119.1lbs
Environmental Considerations	Operating Temperature : 0°C to 40°C Humidity : 0 to 90% Altitude: 0 -10,000 feet Storage Temperature : -10°C to 55°C Humidity: 0 to 90% Altitude: 0-45,000 feet
Regulations :	UL Approved (UL 1950) CSA certified Meets FCC class A requirements Meets DHHS requirements
RGB Input Terminals	RGB 1 : D-SUB 15pin RGB 2 (R, G, B, H/CS and V) Video : Analog 0.7Vp-p/75 Ohm (Positive) Sync. : Separate Sync. TTL level Horizontal Sync. (Positive/Negative) Vertical Sync. (Positive/Negative) : Composite Sync. TTL Level (Positive/Negative) : Composite sync. On green Video 0.3Vp-p (Negative) 0.7 - 5Vp-p/75 Ohm RGB 2 only

RGB Output Terminals. THROUGH OUT	RGB 1 : D-SUB 15pin RGB 2 : BNC (R, G, B, H/CS and V)
Video Input Terminals VIDEO 1/2 S-VIDEO (Video 1/2)	1.0Vp-p, 75 Ohm unbalanced (BNC-Jack), Composite video signal, Sync-negative. Y : 1.0Vp-p, 75 Ohm unbalanced, Sync-negative. C : 0.28Vp-p, 75 Ohm unbalanced, Color burst level.
Video Output Terminals THROUGH OUT (Video 1, 2) THROUGH OUT (S-VIDEO 1, 2)	1.0Vp-p, 75 Ohm unbalanced (BNC Jack), Composite video signal, Sync-negative. Y : 1.0Vp-p, 75 Ohm unbalanced, Sync-negative. C : 0.28Vp-p, 75 Ohm unbalanced, Color burst level.
Audio Input Terminals VIDEO 1, 2 / RGB	Left (Mono) : 0.5 Vrms, high impedance (Pin-Jack) Right : 0.5Vrms, high Impedance (Pin-Jack)
Audio Output Terminals THROUGH OUT	Left : 0.5 ± 0.1 Vrms, less than 22 K Ohm (Pin-Jack) Right : 0.5 ± 0.1 Vrms, less than 22 K Ohm (Pin-Jack)
External Control (IN/THROUGH OUT)	D-SUB 9pin (IN/THROUGH OUT)

SOUND Output Internal External	2.5W+2.5W (THD 10%) at 16 Ohm 5W+5W (THD 10%) at 8 Ohm
Speaker	Oval type 9 X 5.5 cm 16 Ohm, 2pcs.

All specifications are subject to change without notice.

LOCATION AND FUNCTIONS OF CONTROLS

Front Panel

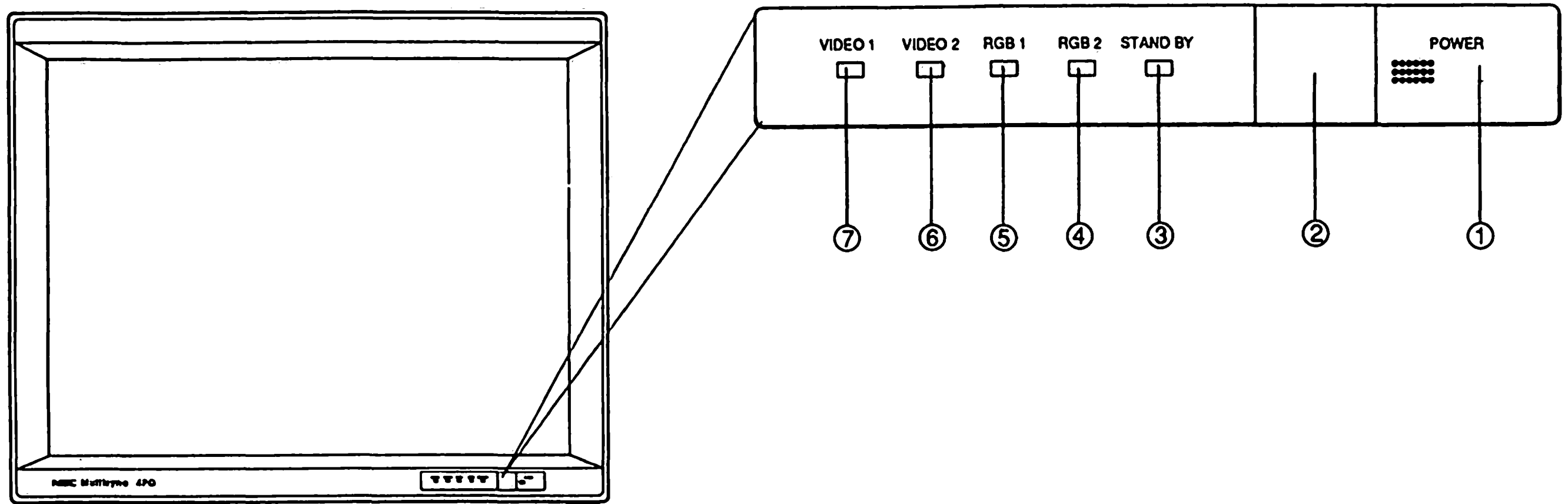

① **POWER** Press to power the monitor on and off.

② **Remote Sensor Window** Receives infrared signal from the remote control unit.

③ **STANDBY Indicator** Indicates the monitor may be turned on using the POWER ON key on the remote control unit.

④ **RGB 2 Indicator** Indicates the RGB 2 button ⑪ is set to receive signals from components connected to the RGB 2 input terminals (R, G, B, H/CS, V).

⑤ **RGB 1 Indicator** Indicates the RGB 1 button ⑩ is set to receive signals from components connected to the RGB 1 input terminal (D-SUB 15 pin).

⑥ **VIDEO 2 Indicator** Indicates the VIDEO 2 button ⑧ is set to receive signals from components connected to the VIDEO 2 input terminal (BNC type or S-VIDEO 2 IN).

⑦ **VIDEO 1 Indicator** Indicates the VIDEO 1 button ⑨ is set to receive signals from components connected to the VIDEO 1 input terminal (BNC type or S-VIDEO 1 IN).

Terminal Board (Left)

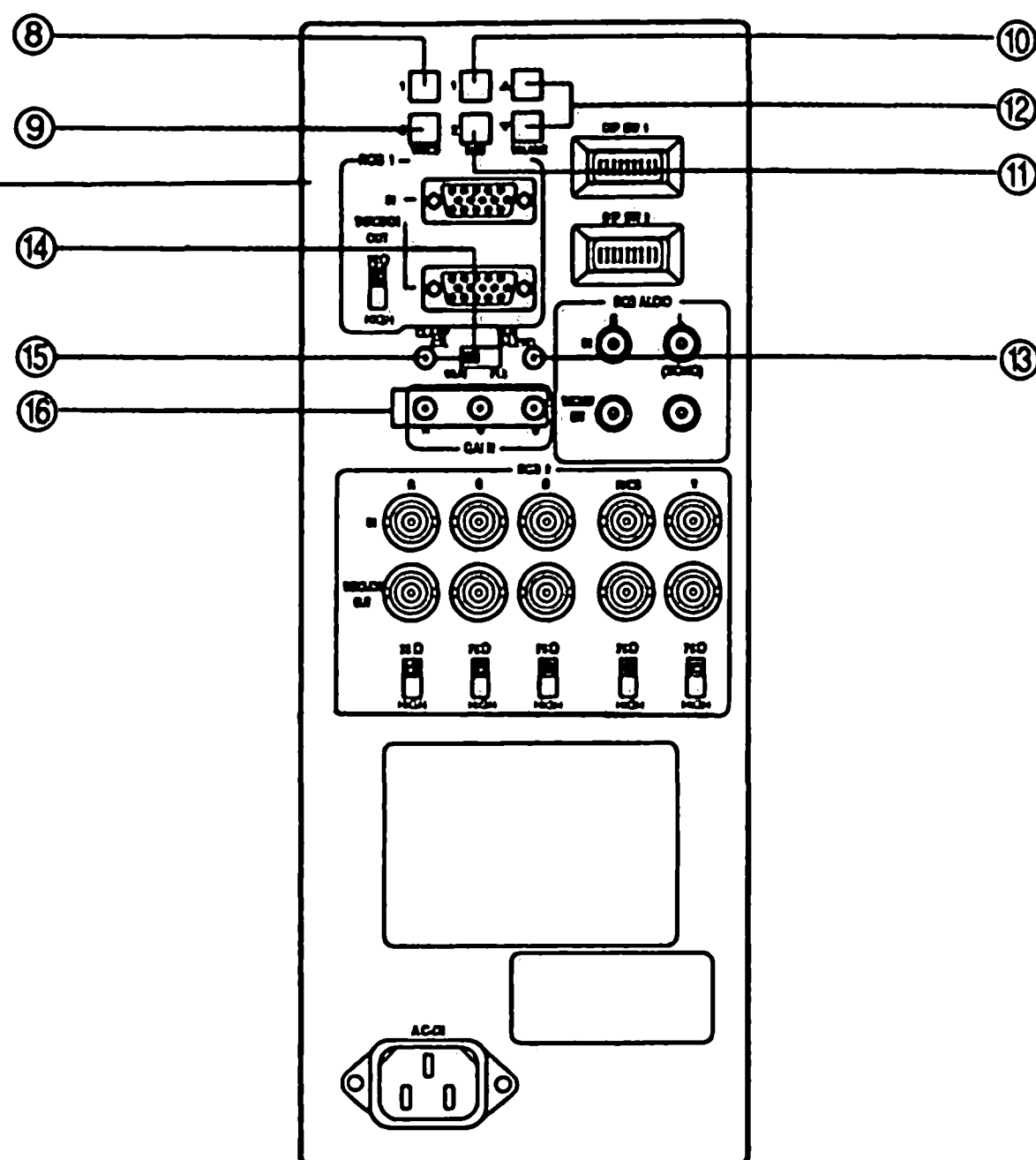
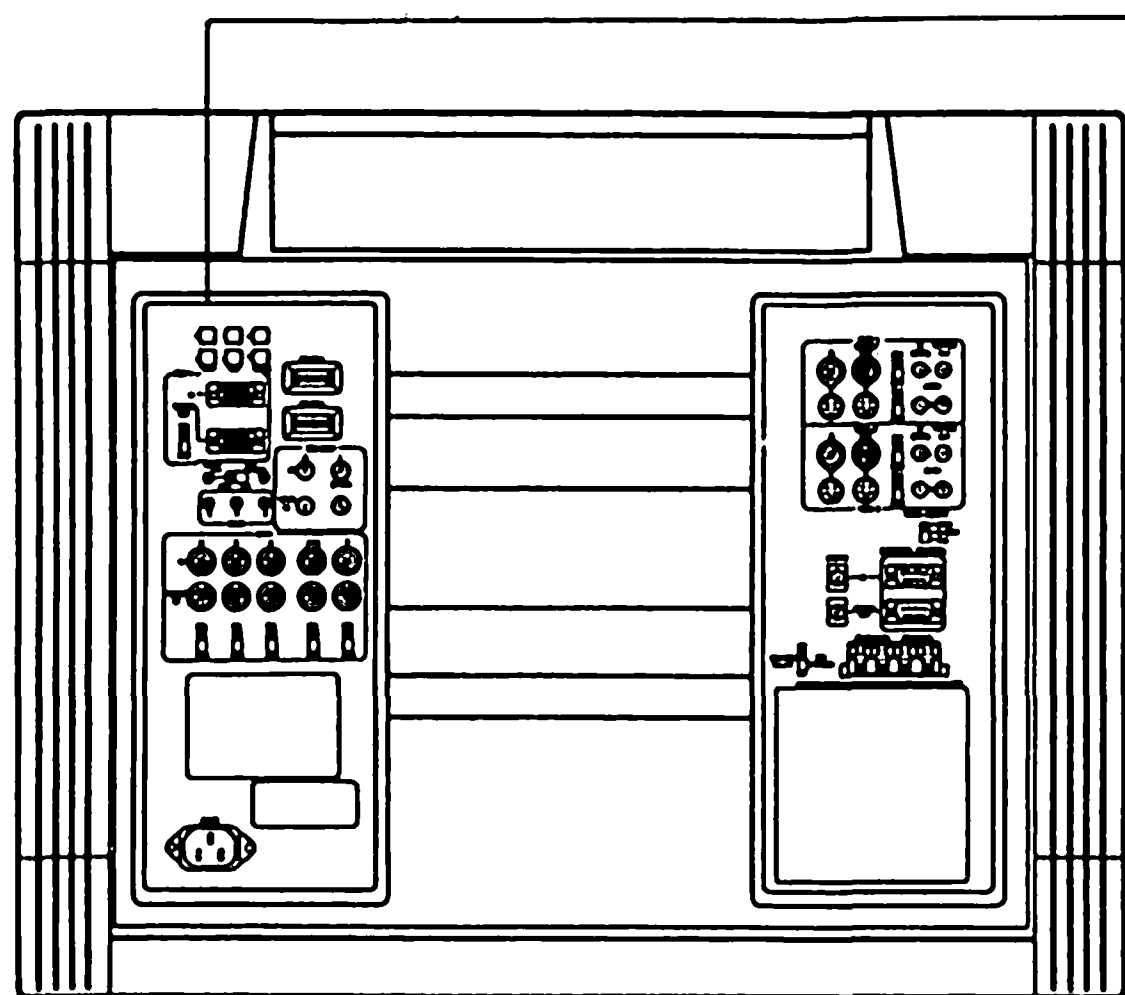

- ⑧ VIDEO 1 Press to select reception of a component connected to the VIDEO 1 input terminal (BNC type or S-VIDEO 1 IN).
- ⑨ VIDEO 2 Press to select reception of a component connected to the VIDEO 2 input terminal (BNC type or S-VIDEO 2 IN).

NOTE: S-VIDEO IN terminals will take preference over VIDEO IN terminals when components are connected to each terminal and VIDEO 1 or 2 selected.

- ⑩ RGB1 Press to select reception of a component connected to the RGB 1 input terminal (D-SUB 15 pin).
- ⑪ RGB 2 Press to select reception of a component connected to the RGB 2 input terminals (R, G, B, H/CS, and V).

- ⑫ VOLUME (▼/▲) Press and hold ▼ to decrease sound.
Press and hold ▲ to increase sound.
- ⑬ SUB B-LEVEL To be adjusted by service personnel only.
- ⑭ CLAMP CTL FIX/VARI
Select Switch Use to select either FIX or VARI setting.
It should normally be set to the FIX position.
When adjusting the clamp pulse position by using CLAMP CTL, set to the VARI position.
- ⑮ CLAMP CTL To be adjusted by service personnel only.
Turn to adjust the clamp pulse position.
- ⑯ R,G, B GAIN To be adjusted by service personnel only.
Turn to adjust each gain for Red, Green and Blue.

LOCATION AND FUNCTIONS OF CONTROLS

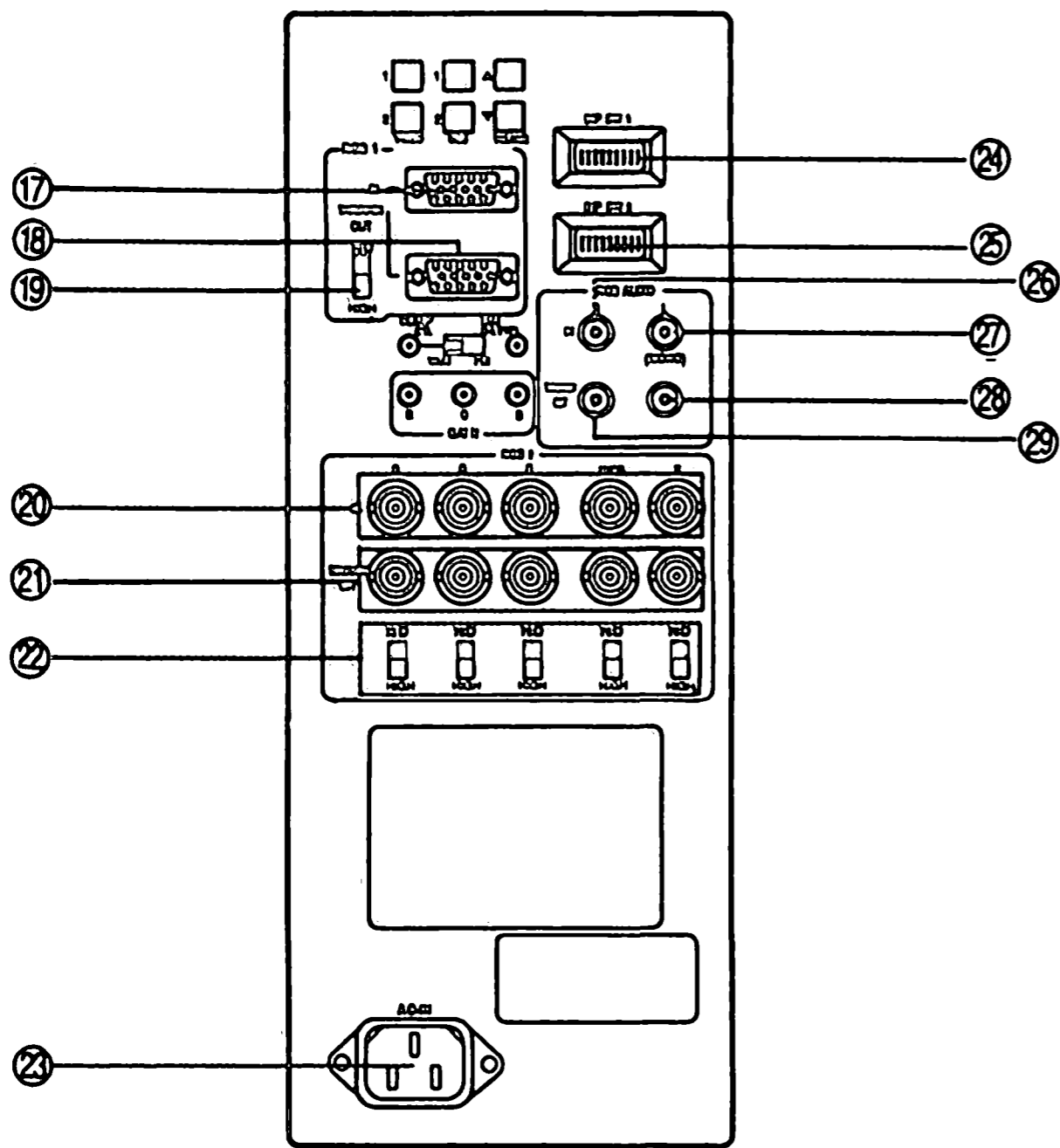

RGB 1

- ⑰ D-SUB 15 PIN INA 15 Pin Analog RGB 1 input terminal compatible with computers that have a VGA output signal.
- ⑱ D-SUB 15 PIN THROUGH OUT Connect to RGB INPUT terminal on the *IBM monitor (#8512, #8513, #8514 or equivalent).
- ⑲ 75 Ω /HIGH Impedance Select SwitchSet to "75 Ω " during normal operation. Set to "HIGH" when using the D-SUB 15 PIN THROUGH OUT RGB 1 terminal.

RGB 2

- ⑳ R, G, B, H/CS, and V IN (BNC)These are analog RGB input terminals. Connect external components with R, G, B, H, and V output terminals to these analog RGB input terminals. Be sure that the RGB connection cable is correctly attached to the corresponding terminals. When connecting devices where the sync signal is an H/V composite signal, connect it to the H/CS terminal.

- ㉑ R, G, B, H/CS, and V THROUGH OUT(BNC) Connect to a second monitor's RGB inputs to relay the RGB signal inputs at R, G, B, H/CS, and V IN ㉑.
- ㉒ 75 Ω /HIGH Impedance Select SwitchSet to "75 Ω " during normal operation. In multiple connections using R, G, B, H/CS, and V IN ㉑ and OUT ㉑ terminals, set to "HIGH" on all but the last monitor. Set to "75 Ω " on the last monitor only.
- ㉓ AC IN Connect the supplied power cord's three-pin plug here.
- ㉔ DIP SW 1 This DIP switch sets each operating mode of the monitor. See page 18 and 19 for more details.
- ㉕ DIP SW 2 This DIP switch sets Sync. Control and also used as D-SUB 15 PIN termination switch. Set all eight pins to the OFF position during normal operation. See pages 20-22 for more details.

- ㉖ R RGB AUDIO IN Connect the audio right channel output of the RGB component.
- ㉗ L RGB AUDIO IN (MONO) Connect the mono audio or stereo left channel output of the RGB component.
- ㉘ L RGB AUDIO THROUGH OUT Connect to a second monitor's audio left channel RGB input.
- ㉙ R RGB AUDIO THROUGH OUT Connect to a second monitor's audio right channel RGB input.

Terminal Board (Right)

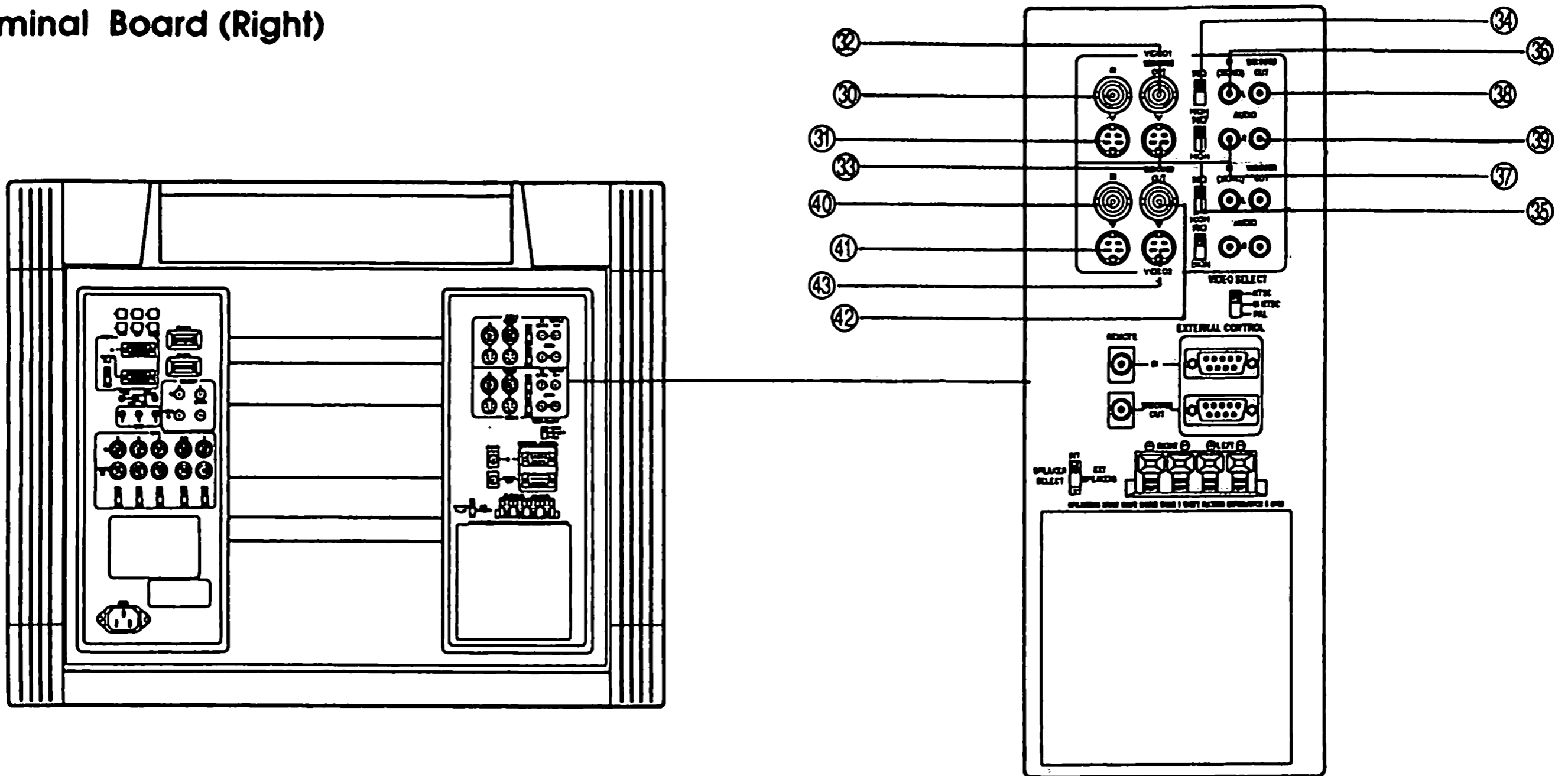

VIDEO 1

- ③ VIDEO 1 IN (BNC) Connect external video component output here.
- ④ S-VIDEO 1 IN Connect external components with S-CONNECTOR output here.
- ⑤ THROUGH OUT (BNC) Connect to a second monitor's video input to relay the video signal input at VIDEO 1 IN ③.
- ⑥ THROUGH OUT (S-VIDEO) Connect to a second monitor's S-CONNECTOR input to relay the video signal input at S-VIDEO 1 IN ④.
- ⑦ 75 Ω /HIGH Impedance Select Switch Set to "75 Ω " during normal operation. In multiple connections using VIDEO 1 IN ③ and THROUGH OUT (BNC) ⑤ terminals, set to "HIGH" on all but the last monitor. Set to "75 Ω " on the last monitor only.
- ⑧ 75 Ω /HIGH Impedance Select Switch Set to "75 Ω " during normal operation. In multiple connections using S-VIDEO 1 IN ④ and THROUGH OUT (S-VIDEO) ⑥ S-CONNECTOR terminals, set to "HIGH" on all but the last monitor. Set to "75 Ω " on the last monitor only.

- ⑨ L AUDIO IN (MONO) Connect external component mono audio or stéreo left channel audio output here.
- ⑩ R AUDIO IN Connect external component stereo right channel audio output here.
- ⑪ L AUDIO OUT Connect to a second monitor's audio left channel input.
- ⑫ R AUDIO OUT Connect to a second monitor's audio right channel input.

VIDEO 2

- ⑬ VIDEO 2 IN (BNC) Connect external component video output here.
- ⑭ S-VIDEO 2 IN Connect external component with S-CONNECTOR output here.
- ⑮ THROUGH OUT (BNC) Connect to a second monitor's video input to relay the video signal input at VIDEO 2 IN ⑬.
- ⑯ THROUGH OUT (S-VIDEO) Connect to a second monitor's S-CONNECTOR input to relay the video signal input at S-VIDEO 2 IN ⑭.

LOCATION AND FUNCTIONS OF CONTROLS

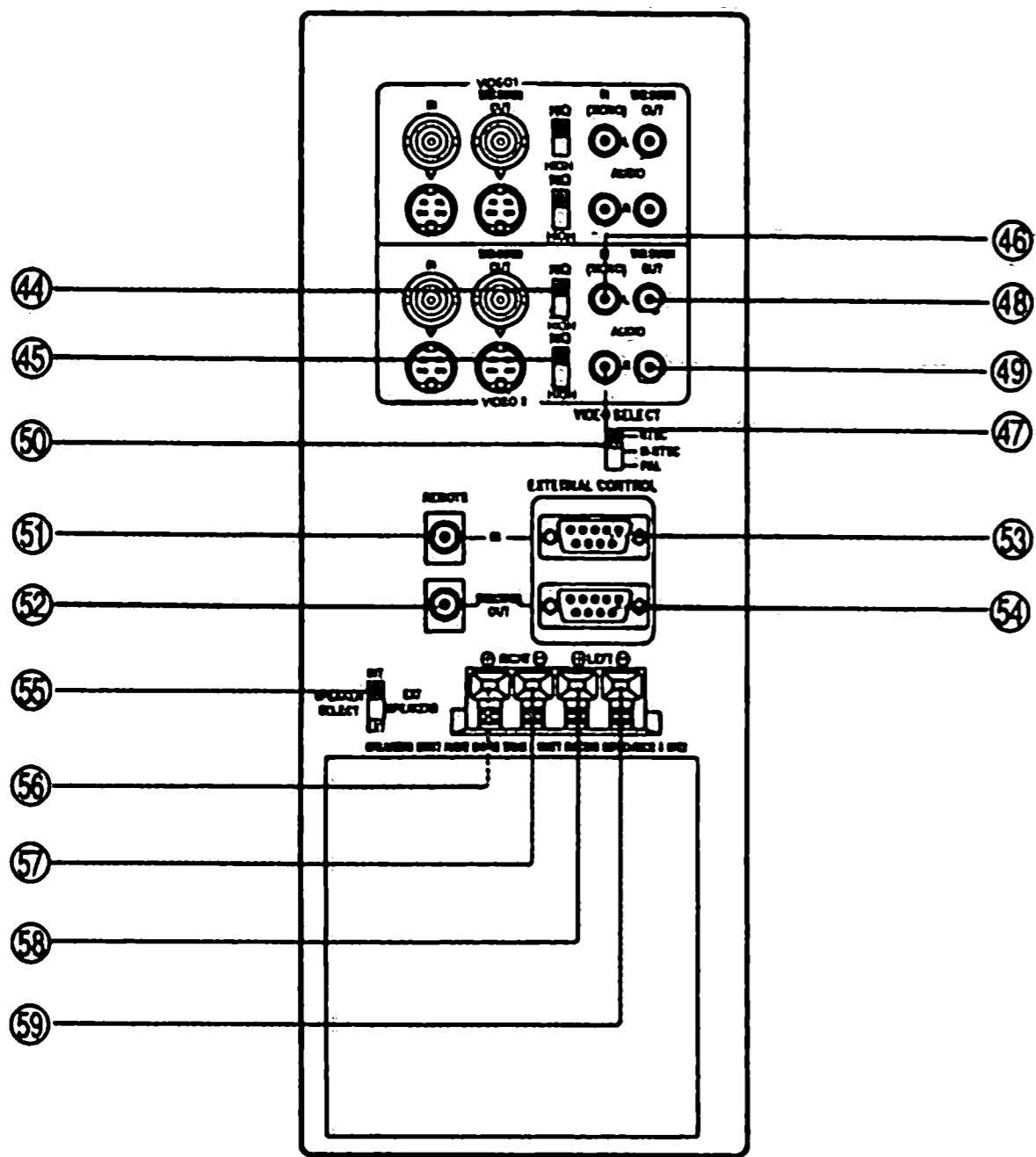

- ④④ 75 Ω/HIGH Impedance Select Switch Set to "75 Ω" during normal operation. In multiple connections using VIDEO 2 IN ④④ and THROUGH OUT (BNC) ④⑤ terminals, set to "HIGH" on all but the last monitor. Set to "75 Ω" on the last monitor only.
- ④⑤ 75 Ω/HIGH Impedance Select Switch Set to "75 Ω" during normal operation. In multiple connections using S-VIDEO 2 IN ④① and THROUGH OUT (S-VIDEO) ④② S-CONNECTOR terminals, set to "HIGH" on all but the last monitor. Set to "75 Ω" on the last monitor only.
- ④⑥ L AUDIO IN (MONO) Connect external component audio mono or stereo left channel output here.
- ④⑦ R AUDIO IN Connect external component audio stereo right channel output here.
- ④⑧ L AUDIO OUT Connect to a second monitor's audio left channel input.
- ④⑨ R AUDIO OUT Connect to a second monitor's audio right channel input.
- ⑤① VIDEO SELECT Switch Set switch to NTSC, M-NTSC or PAL depending on the selected video signal format. It should normally be set to NTSC.

⑤①/⑤② REMOTE IN/OUT When the supplied remote control is used in the wired condition, connect the supplied remote cable to the REMOTE IN terminal. The REMOTE OUT terminal is used to connect several monitors together and allows all of the monitors to be controlled by one remote control.

NOTE: Up to 50 monitors can be connected in the serial connection.

⑤③ EXTERNAL CONTROL
 Input This terminal is used when power ON/OFF, Input selection, AUDIO MUTE, PICTURE MUTE, and DEGAUSS are operated externally (by external control). See also page 36 for the external control port pin assignments.

NOTE: Select EXT. CONTROL ON by setting pin No.7 of DIP SW 1 to ON when operating the monitor by external control.

NOTE: When in the EXT. CONTROL mode, the following operations of the supplied remote control are not possible: Power control ON/OFF, Input selection, Audio mute ON/OFF, and Degauss switch ON/OFF.

⑤④ EXTERNAL CONTROL THROUGH OUT Connect to a second monitor's EXTERNAL CONTROL input to relay the signal Input at the EXTERNAL CONTROL IN ⑤③. The EXTERNAL CONTROL THROUGH OUT terminal is used to connect several monitors together (up to 50) and allows all of the monitors to be controlled by one external control. No.7 pin (EXT. CONTROL) of DIP SW 1 ②④ must be set to the ON position on all of the monitors.

⑤⑤ SPEAKER SELECT INT/EXT Set to the INT position for built-in monitor speakers. Set to the EXT position for speakers connected to EXT SPEAKERS terminals.

- ⑤⑥ + RIGHT Connect RIGHT speaker positive wire here.
- ⑤⑦ - RIGHT Connect RIGHT speaker negative wire here.
- ⑤⑧ - LEFT Connect LEFT speaker negative wire here.
- ⑤⑨ + LEFT Connect LEFT speaker positive wire here.

Remote Control Unit

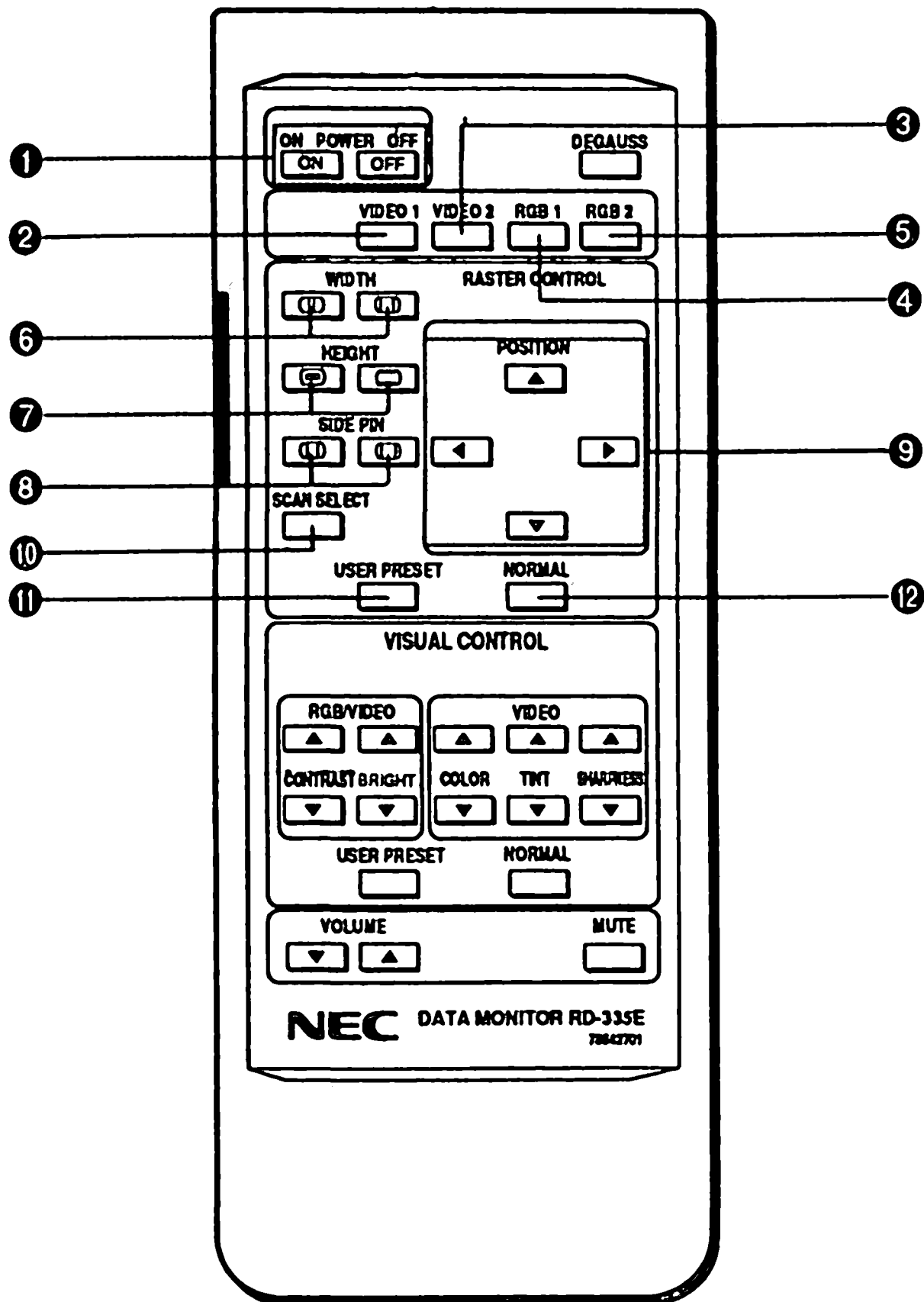

- ① **POWER ON/OFF** Press POWER ON to turn the monitor on when the STANDBY indicator is lit. Press POWER OFF to turn the monitor off and the monitor will go into the standby condition.
- ② **VIDEO 1** Press to select reception of a conventional component or S-connector component connected to VIDEO 1 IN terminal.
- ③ **VIDEO 2** Press to select reception of a conventional component or S-connector component connected to VIDEO 2 IN terminal.
- ④ **RGB1** Press to select reception of a component connected to RGB 1 IN terminal.
- ⑤ **RGB 2** Press to select reception of a component connected to RGB 2 IN terminal.

Raster Control

- ⑥ **WIDTH** (/) Adjusts the horizontal size of the image from wider to narrower.
- ⑦ **HEIGHT** (/) Adjusts the vertical size of the image from taller to shorter.
- ⑧ **SIDE PIN** (/) Adjusts the curvature of the edges of the left and right side of the display image either inward or outward. The image should be adjusted to attain a straight line on the left and right sides.

- ⑨ **POSITION** (/ / /) ... Adjusts the vertical position of the image up and down, and the horizontal position of the image from left to right.

- ⑩ **SCAN SELECT** Pressing this button toggles picture size between OVER SCAN (large) and UNDER SCAN (small).

Normally select OVER SCAN for video display and UNDER SCAN for RGB display.

- ⑪ **USER PRESET** Press to store the raster adjustments (WIDTH, HEIGHT, SIDE PIN, POSITION, and SCAN SELECT) in the memory. Storing operation should be performed for each input signal.

See "Signal Identification Flowchart" on pages 44 and 45.

NOTE: The monitor will recall the raster adjustment settings that were stored last when switched to a new source.

- ⑫ **NORMAL** This key resets the raster adjustment settings of user changeable memory and recalls the factory preset data.

LOCATION AND FUNCTIONS OF CONTROLS

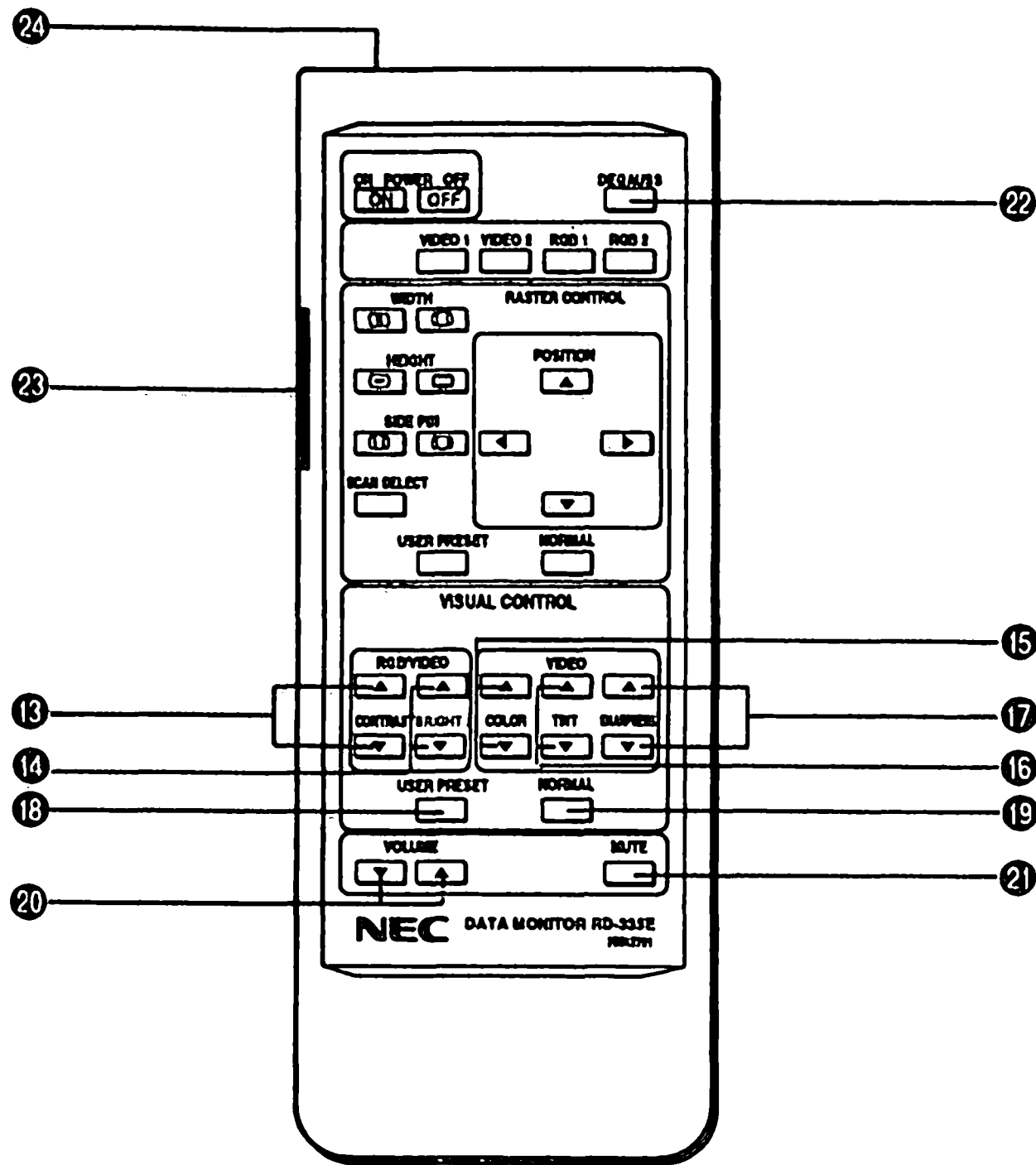

Visual Control

- ⑬ RGB/VIDEO
CONTRAST (▲ / ▼) Used to adjust contrast of video or RGB display.
Press and hold ▲ for higher contrast.
Press and hold ▼ for lower contrast.
- ⑭ RGB/VIDEO
BRIGHT (▲ / ▼) Used to adjust brightness of video or RGB display.
Press and hold ▲ for a brighter picture.
Press and hold ▼ for a darker picture.
- ⑮ COLOR (▲ / ▼) Used to adjust color intensity of video display.
Press and hold ▲ for more color saturation.
Press and hold ▼ for less color saturation.
- ⑯ TINT (▲ / ▼) Used to adjust red and green values of video display.
Press and hold ▲ for a greener tint.
Press and hold ▼ for a redder tint.
This control does not work for the PAL signal.
- ⑰ SHARPNESS (▲ / ▼) Used to adjust picture detail of video display.
Press and hold ▲ for a sharper picture.
Press and hold ▼ for a softer picture.
- ⑱ Backlight Switch Set to ON to light up keys from the inside of the remote control panel.
This is useful when the remote control unit is used in a darkened room.

NOTE: The COLOR, TINT and SHARPNESS keys only work for the video display.

- ⑲ USER PRESET Press to store the picture adjustments (CONTRAST, BRIGHT, COLOR, TINT and SHARPNESS) in the memory.

NOTE: The VISUAL CONTROL storing operation is effective only for one input (VIDEO1, VIDEO2, RGB1 or RGB2).

- ⑲ NORMAL This key resets the picture adjustment settings of user changeable memory and recalls the factory preset data.

NOTE: The CONTRAST, BRIGHT, COLOR, TINT and SHARPNESS adjustment level are factory preset at the optimum position.

- ⑳ VOLUME (▼ / ▲) Used to adjust the volume.
Press and hold ▼ to decrease sound.
Press and hold ▲ to increase sound.
- ㉑ MUTE Press to cancel sound ; press again to restore sound.

NOTE: The other ways to restore sound are to press POWER ON/OFF and VOLUME keys on the remote control unit.

- ㉒ DEGAUSS This key is used to demagnetize the picture tube in the manual operation. See also page 35.

NOTE: The backlight key characters may be invisible in a bright-lit room. Make sure that the backlight switch is OFF when the remote control unit is not used.
If no button operation is made within 30 seconds when the backlight switch is ON in the wireless condition, the backlight go off automatically. To turn the backlight on again, set the switch to the OFF position, then set it to the ON position.

- ㉒ Remote Jack Insert the plug of the supplied remote cable when using the supplied remote control unit in the wired condition. Connecting the monitor and the remote control unit with the supplied remote cable turns on the backlight when the switch is set to the ON position.

ADJUSTMENT PROCEDURES

Adjusting Items

1. Power Supply Check
2. Horizontal Oscillation Adjustment
 - 2-1. Horizontal adjustment I (DEF SUB PWB single adjustment)
 - 2-2. Horizontal adjustment II (RGB PWB single adjustment)
3. Vertical Oscillation Adjustment
 - 3-1. Vertical adjustment I
 - 3-2. Vertical adjustment II (RGB PWB single adjustment)
4. High Voltage Adjustment
 - 4-1. Adjustment of High Tension (Adjustment of DEF SUB DEF/HV PWB unit)
 - 4-2. Adjustment of high-tension protector (DEF SUB DEF/HV PWB unit)
5. Video Chroma Circuit Adjustment
 - 5-1. PAL Comb Filter Adjustment
 - 5-2. Sub Bright and Sub-Contrast Adjustments
 - 5-3. PAL Matrix Adjustment
 - 5-4. Auto Phase Control Adjustment
6. Horizontal Width Adjustment
7. Vertical Linearity Adjustment
8. Vertical Height Adjustment
9. Side Pin Cushion Adjustment
10. Keystone Adjustment
11. Image Tilt Correction
12. White Balance Procedure
13. Audio Circuit Adjustment
14. Raster D/A Control Setting
15. Video D/A Control Setting
16. Dynamic Focus Waveform Adjustment
17. Focus Adjustment
18. High-Voltage Protector Circuit Operation Verification

ADJUSTMENTS PROCEDURES

1. Power Supply Check

- (1) Verify input voltage is 120VAC/60Hz.
- (2) Verify the following μ COM/V PWB voltages.
DC1-DC5 = 8.5Vdc, DC3-DC5 = 27Vdc, DC4-DC5 = 27Vdc.
- (3) Verify that μ COM/V PWB DC2-DC5 = 40Vdc.

2. Horizontal Oscillation Adjustment

2-1 SUB PWB Horizontal Oscillation Adjustment

- (1) Input a horizontal frequency of 50.0 KHz to either RGB1 or RGB2.
- (2) Short connector pins 6 and 4 of "JA" of the μ COM/V PWB (PWC-3839).
- (3) Adjust VR9001 of the DEF SUB PWB (PWC-3856A) so that there is one image.
- (4) Input the NTSC Split field pattern and adjust VR9002 (DEF SUB PWB) so that there is one image.
- (5) Repeat steps (3) and (4) and verify proper 15.75 and 50.0kHz sync performance.
- (6) Open the connector pins 6 and 4 of "JA" of the μ COM/V PWB.
Note: Shorting JA pins 4 and 6 puts the horizontal oscillator into Free Run mode.

2-2 RGB PWB Horizontal Oscillation Adjustment

- (1) Input an NTSC color bar signal to CH1 of your oscilloscope.
- (2) Connect CH2's probe to TP8701 and TP GND1.
- (3) Adjust VR8701 (H-SYNC FREE RUN ADJ) so that CH1 and CH2 are in sync with each other .
Note: This is a free run adjustment so do NOT input video signal to monitor for this adjustment.

3. Vertical Oscillation Adjustment

3-1 DEF SUB PWB Vertical Oscillation Adjustment

- (1) Input VGA3 (480 line) to either RGB1 or RGB2 input.
- (2) Short the connectors pins 5 and 4 of "JA" of the μ COM/V PWB (PWC-3839).
- (3) Connect a digital counter, or oscilloscope, to TP4001 of the DEF SUB PWB (PWC-3856A).
- (4) Adjust VR4001 so that TP4001 (DEF SUB PWB) equals 50 ± 0.5 Hz.
- (5) Open connectors pin 5 and 4 of "JA" of the μ COM/V PWB and disconnect the digital counter (or scope).

3-2 RGB PWB Vertical Oscillation Adjustment

- (1) Set the VIDEO SELECT SW (VIDEO I/O PWB) to the NTSC mode.
Note: Do not connect the video input for this free run adjustment.
- (2) Connect the oscilloscope or frequency counter to TP8702 on the RGB PWB (PWC-3836).
(Be sure to utilize the TPGND1 as the ground for the probe.)
- (3) Adjust VR8702 (FREE RUN ADJ) so that TP8702 equals 18.18 ± 0.3 mSec.

4. High Voltage Adjustment

4-1 DEF SUB and DEF/HV High Voltage Adjustments

- (1) Connect a high voltage probe under the CRT's anode cap User High Voltage probe whose maximum voltage is rated more than 1.5kV and has internal an impedance Greater than 1000MΩ.
- (2) Input all black video signal.
- (3) Set the VR of the FBT (DEF/HV PWB T5001) to the MIN position.
- (4) Adjust VR9003 (DEF SUB PWB) so that the high voltage equals $29 \pm 0.3 \text{Vdc}$.
- (5) Remove the high voltage probe and seal VR9003 with silicone and a cap to comply with DHHS requirements.

4-2 DEF SUB and DEF/HV High Voltage Protector Adjustment

- (1) Input NTSC all black video signal and turn FBT Screen VR fully counterclockwise.
- (2) Connect the voltmeter first to TP2001-TP GND and then TP2002-TP GND and adjust VR2001 so that TP2001-TP GND = TP2002-TP GND, approximately 8.8Vdc.
- (3) Remove the voltmeter from the circuit and seal VR2001 with silicone and a cap to comply with DHHS requirements.

5. Video Chroma Circuit Adjustment

5-1 PAL Comb Filter Adjustment

- (1) Input the PAL color bar signal.
- (2) Set the Video Select SW to "PAL".
- (3) Connect the oscilloscope to TP7003 on the Video PWB.
- (4) Adjust VR7101 and T7101 and set the chroma signal component to the MIN position.
Note: VR7101, T7101, and TP7003 on the Video PWB (PWC-3838A).

5-2 Sub-Bright and Sub-Contrast Adjustments

- (1) Input the NTSC 16 gradation gray scale pattern which must have 0% all-black and 100% all-white shades.
- (2) Set the Video Select SW to the "NTSC" position.
- (3) Connect the oscilloscope to TP7001 (Green signal) and TP GND.
- (4) Adjust VR7202 (SUB-BRIGHT) and VR7201 (SUB-CONT) until the waveform appears as shown below.

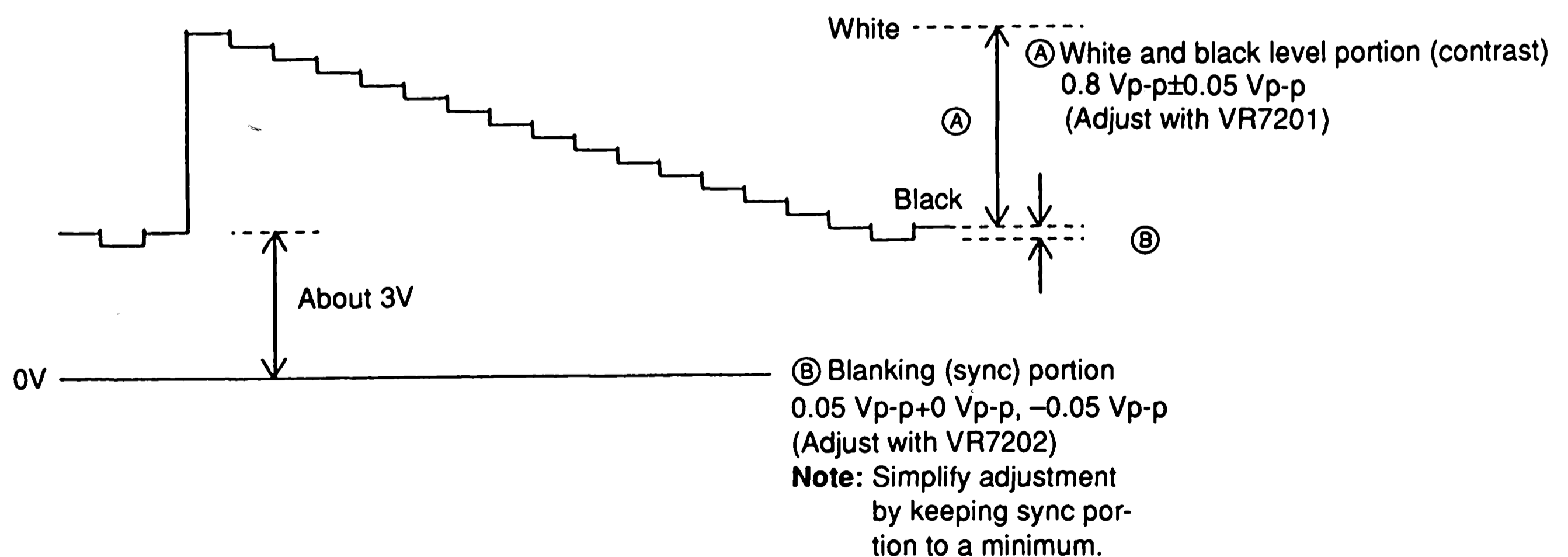

Note: TP7001, VR7201, VR7202, and TP GND are on the Video PWB.

Also correct wave forms are easier to read and adjust when the scope's probe is grounded at TP GND (Video PWB).

ADJUSTMENTS PROCEDURES

5-3 PAL Matrix Adjustment

- (1) Input the PAL "DEM" signal and set the color to MAX position.
- (2) Set the Video Select SW to "PAL".
- (3) Connect the oscilloscope to TP7002.
- (4) Adjust VR7402 (Delay Adj.) so that amplitudes of No. 1 and No. 2 are as shown below.

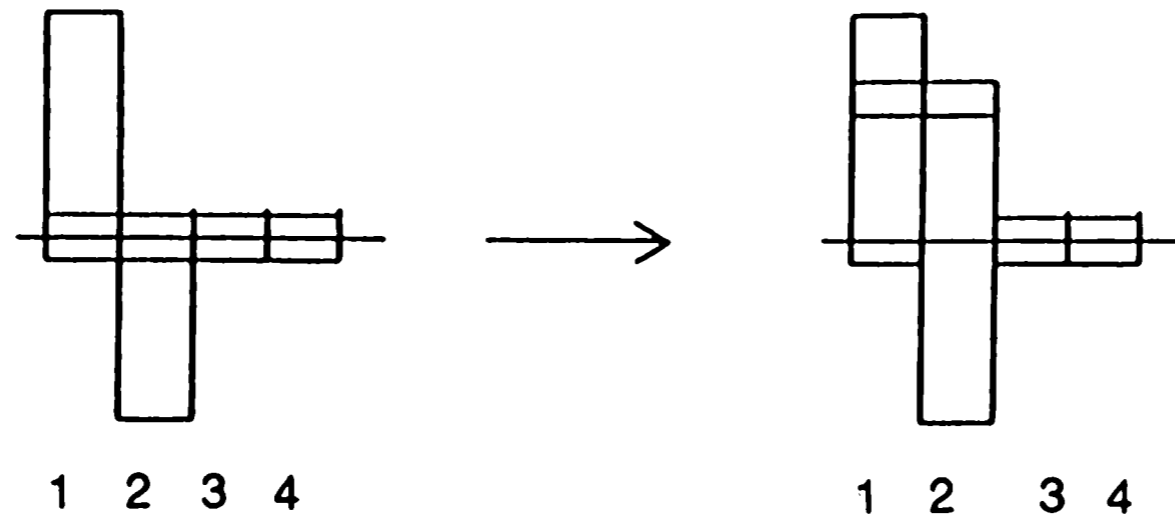

- (5) Adjust T7401 (Delay Matching Adj) so that amplitudes of No. 1 and No. 2 are as shown below.

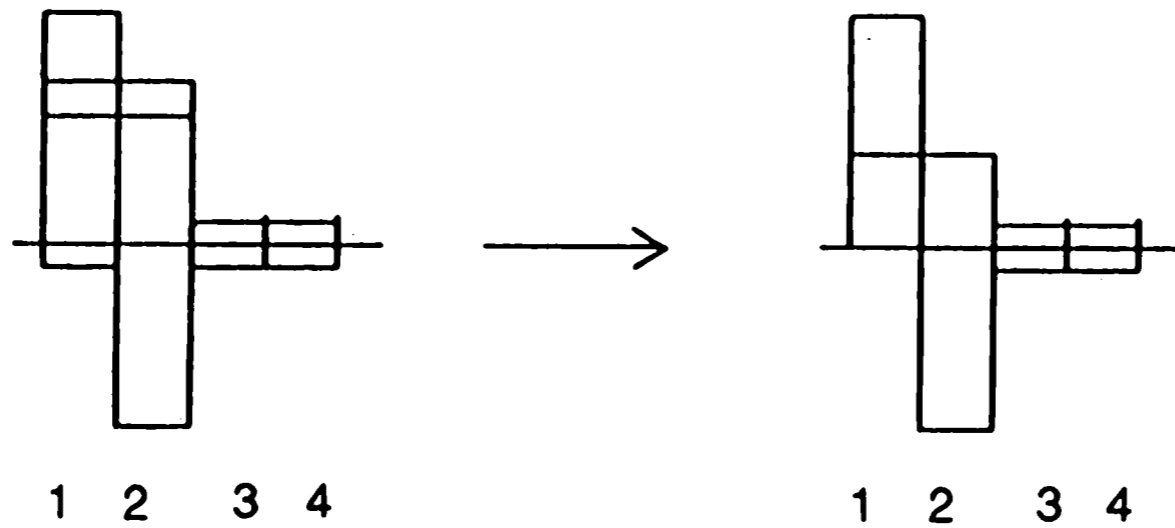

5-4 Auto Phase Control Adjustment

- (6) Adjust VR7401 (APC) so No. 3 and No. 4 are linear as shown below.

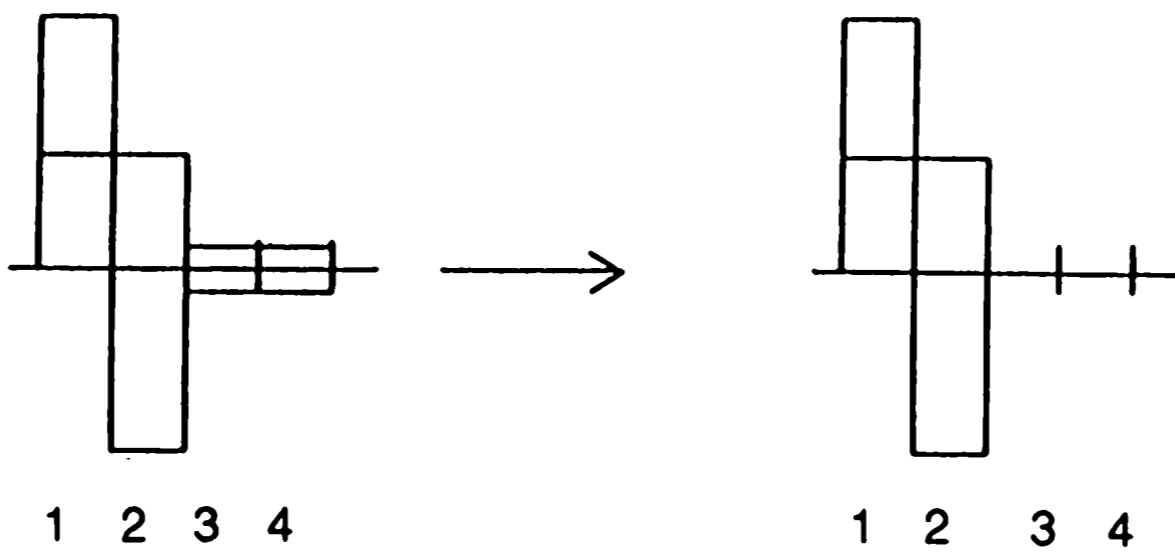

- (7) Lower the brightness and check that there are no bars. Repeat steps (4) to (6) when and as needed. (Set adjustment.)

6. Horizontal Width Adjustment

- (1) Input the PC-98 (400 line) RGB signal.
- (2) Set Scan Select to OVERSCAN mode. Adjust either the remote control or VR4002 (DEF SUB PWB) so that vertical height is 100% scan.
- (3) Set the remote control H. Width to MAX position and adjust VR9004 (DEF SUB PWB) so that horizontal width equals 100% scan.
- (4) If there is side pincushion distortion, adjust either the remote control or VR5505 (μ COM/V PWB) to straighten out the right and left vertical lines. Then Adjust VR9004 as outlined in Step (3).

7. Vertical Linearity Adjustment

- (1) Input the VGA3 (480 line) crosshatch signal to the RGB input.
- (2) Set the Scan Select in the UNDERSCAN mode and adjust the remote control or VR4002 of the DEF SUB PWB so that the vertical height equals 95% scan.
Note: Upper and Lower blanking sections should be 10 ± 2 mm each.
- (3) Adjust VR403 (DEF SUB PWB) for Optimum Vertical linearity performance Make sure that the circles are same size at the top and bottom of the image.

8. Vertical Height Adjustment

- (1) Input the VGA 350 line mode.
- (2) Set the Scan Select SW in the UNDERSCAN mode and set the remote control or V. Height to MAX position.
- (3) Adjust the VR4002 of the DEF SUB PWB so that the vertical amplitude becomes 100% scan.

9. Side Pin Cushion Adjustment

- (1) Input the VGA 480 line mode.
- (2) Press the NORMAL button of the remote control raster control system.
- (3) Set the Scan Select SW in the UNDERSCAN mode and adjust the remote control so that the vertical.
Note: $95\pm 1\%$ scan means that there are two black vertical stripes on either side of the image measuring 14 ± 3 mm in width. Do not touch the side pin button.
- (4) Adjust VR5504 of the μ COM/V PWB so that the video center transverse line becomes straight.
- (5) Adjust VR5505 of the μ COM/V PWB so that the video left transverse line becomes straight.
- (6) Adjust VR5401 of the DEF/HV PWB so that the video left transverse line becomes straight.

10. Keystone Adjustment

- (1) Input the VGA 480 line mode cross hatch signal.
- (2) Set the Scan Select in the UNDERSCAN mode and adjust the remote control so that the vertical height become $95\%\pm 1\%$.
- (3) Adjust the remote control to vertically center the image.
- (4) Adjust VR5501 (μ COM/V PWB) to minimize trapezoidal distortion

11. Image Tilt Correction

- (1) Input the VGA 480 line mode crosshatch signal.
- (2) Set the Scan Select SW in the mode and adjust the remote control so that the vertical height becomes $95\pm 1\%$.
- (3) Adjust VR5503 (μ COM/V PWB) to minimize image tilt.

ADJUSTMENTS PROCEDURES

12. White Balance Procedure

- (1) Set R/G/B GAIN VRs (RGB I/O PWB VR873~VR875) to mechanical center click point. Then, set R/G/B SUB CONT VRs (RGB SUB PWB VR8201~VR8203) Fully counterclockwise.
- (2) Input NTSC video 1/4 window pattern terminated at 75Ω and select Video mode Use the Remote Control to Normalize Contrast. Brightness, Color, Tint and Sharpness settings.
- (3) Slide S8001 (RGB PWB CONTRAST MIN SW) to the ON position.
- (4) Adjust VR872 (RGB I/O PWB SUB BRT) so TP8301-TP GND2 equals 32±0.1Vdc.
- (5) Connect the oscilloscope to the G cathode and adjust VR8402 (RGB PWB Green Bias) so that the black level equals 160Vdc. There is almost no video.
- (6) Adjust VR8401 (red, bias) and VR8403 (blue, bias), just as in the case of the R cathode and B cathode until the black level becomes 160 V DC.
- (7) Set the screen VR (FBT) to MIN position. Input NTSC all black raster pattern.
- (8) Slide S4501 (μCOM/V PWB Cut-off Switch) to the off position (parallel to the CRT).
- (9) Gradually increase the Screen VR until the first horizontal line can be seen. This is the reference color.
- (10) Use the other two non-reference Bias VRs to form a white line. Do not adjust the reference color Bias VR while performing this step.
- (11) Slide S4501 (μCOM/V PWB) to its original position restoring full vertical deflection.
- (12) Slide S8001 (RGB PWB CONTRAST MIN SW) to the OFF position.

Note: Do not turn Reference Bias VR for further white balance adjustments. Also, do NOT adjust FBT Screen VR. If adjusted by accident, repeat Cut-off adjustment procedure Steps (8)-(12).

- (13) Set the CONTRAST of the remote control to MAX position.
- (14) Input NTSC 1/4 window pattern and connect your scope to the Green cathode.
- (15) Adjust VR8202 (RGB PWB) so that the white peak (measured from the black peak) equals 90±0.5Vp-p. Then adjust VR8201 (Red) and VR8203 (Blue) as measured at the Red and Blue Cathodes, respectively.
- (16) Next, perform Bias VR control tracking Remove the scope probe from the cathode.
- (17) Input NTSC 1/4 Window white pattern. Using a Minolta TV2130. CA-100 or similar light meter, set the monitor's light output to 30 cd/m² with the Remote Control Contrast Key Next, Adjust VR8401 (Red), VR8402 (Green) and VR8403 to a Color temperature of 10,500°K (x=0.281±0.005, y=0.285±0.005).
- (18) Now use the remote Control Contrast Key to set the monitor's light output to 150cd/m². Use the same BIAS VRs (VR8401~8403) to set the Color Temperature to 10,500°K (x=0.281±0.005, y=0.285±0.005).

Note: The measurement difference between (17) and (18) is as follows.

$$\Delta[(17) \cdot (18)] = 10,500^\circ\text{K} @ 30\text{cd/m}^2 \cdot 10,500^\circ\text{K} @ 150\text{cd/m}^2 = \pm 0.005$$

$$\text{Where } 10,500^\circ\text{K} : x=0.281, y=0.285$$

- (19) Input VGA3 1/4 window pattern to either RGB1 or RGB2 Adjust Remote Control CONTRAST key to maximum and Brightness to Cutoff. Adjust RGB PWB VR8204 (RGB Red). VR8205 (RGB Green) and VR8206 (RGB Blue) so that the waveform at the each cathode equals 80±0.5Vpp. Remove scope probe upon completion.
- (20) Use light meter and Remote Control Contrast Key to set the monitor's light output to 150cd/m². Adjust VR8204, VR8205 and VR8206 to set Color Temperature to 10,500°K (x= 0.281±0.005, y=0.285±0.005).
- (21) Supply the window signal of 0.7 Vp-p (1/10 H, 1/10V size) using the RGB signals for display. RGB1 or RGB2 may be used, but RGB is basic. ⇒ BNC input.
Adjust the remote control so that the CONTRAST MAX and Brightness black do not crush.
Adjust VR8204 (RGB red), VR8205 (RGB green), and VR8306 (RGB blue) on the RGB PWB so that the video waveform becomes 80 Vp-p +0 V, -5 V until the black peak is turned to white peak at each cathode.
- (22) Set the white balance of the RGB signal with the brighter white balance.
⇒ Remove the probe of the oscilloscope in advance.
⇒ VRs are VR8204 (RGB red), VR8205 (RGB green), and VR8204 (RGB blue).
⇒ Adjust the brightness level to 150 cd/m² and the color temperature should be adjusted to 10500K (X =281±5 and Y = 285±5).

13. Audio Circuit Adjustment

- (1) Input a sine wave of 1 KHz, 0.5 V rms to the video 1 L-ch audio input terminal. (A video signal is not required to perform this adjustment).
- (2) Select the video 1.
- (3) Connect the 8Ω dummy load (10 W rating or more) to the external speaker terminals (L-ch and R-ch).
- (4) Set the speaker INT/EXT SW to the EXT position.
- (5) Set the VOLUME key so that both end voltages of the dummy load (L-ch) become about 5 V rms (about 14 Vp-p, about 3 watts).
- (6) Adjust the VR301 (Input Level Adj. on the μCOM/V PWB) so that both end voltages of the dummy load (R-ch) become the same as the voltage set in (5).

Note: The difference between the L-ch and R-ch shall be the deviation within 1 Vp-p (within 7%).

14. Raster D/A Control Setting

- (1) Input an NTSC crosshatch pattern.
- (2) Set the CONTRAST and B-LEVEL to the center, using the remote control.
- (3) Connect the wire between pin 1 and pin 7 of connection JB on μCOM/V PWB (PWC-3839) [TEST MODE].
- (4) Set the monitor to the OVERSCAN mode using the scan select key of the remote control.
- (5) Set the CONTRAST of the remote control to the to MAX position using the CONTRAST key.
- (6) Adjust the video signal to the center, overscan 7±2% using the H WIDTH UP/DOWN key, V HEIGHT UP/DOWN key, H POSITION LEFT/RIGHT key, and V POSITION UP/DOWN key.
- (7) Next, press the Remote Control NORMAL key to store these new values.
- (8) Next, input the PAL monoscope signal and repeat steps (2) to (7) by setting the Video I/O PWB NTSC/PAL Switch accordingly.

Note: Either Video1 or Video2 can be used for this step.

- (9) Next, Input VGA2 (350 line mode)
- (10) Set the monitor into the UNDERSCAN mode using the Scan Select key of the remote control.
- (11) Make adjustment so that this RGB image is centered at 95±2% scan, just as in the case of the video signal.
- (12) Next, press the Remote Control NORMAL key to store these new values.

- (13) Perform steps (9)~(12) for each of the following inputs:
VGA2, VGA3, MACII and VESA (8x6 @ 72Hz and 10x7 @ 60Hz).

Note: Use the Remote Control V-Position Control to move image up and down to minimize trapezoidal distortion.

- (14) Upon completion of (1)~(13), connect the wire between pin 1 and pin 7 of connector JB on μCOM/V PWB (PWC-3839) [TEST MODE], and connect the wire between pin 2 and pin 5 of connector JB [AUTO Transfer Mode]. Factory Preset data is copied into User memory area.
- (15) After two seconds, disconnect the wire between pin 2 and pin 5 of connector JB, and between pin 1 and pin 7 of connector JB.

Table [Preset Signal Timing Chart]

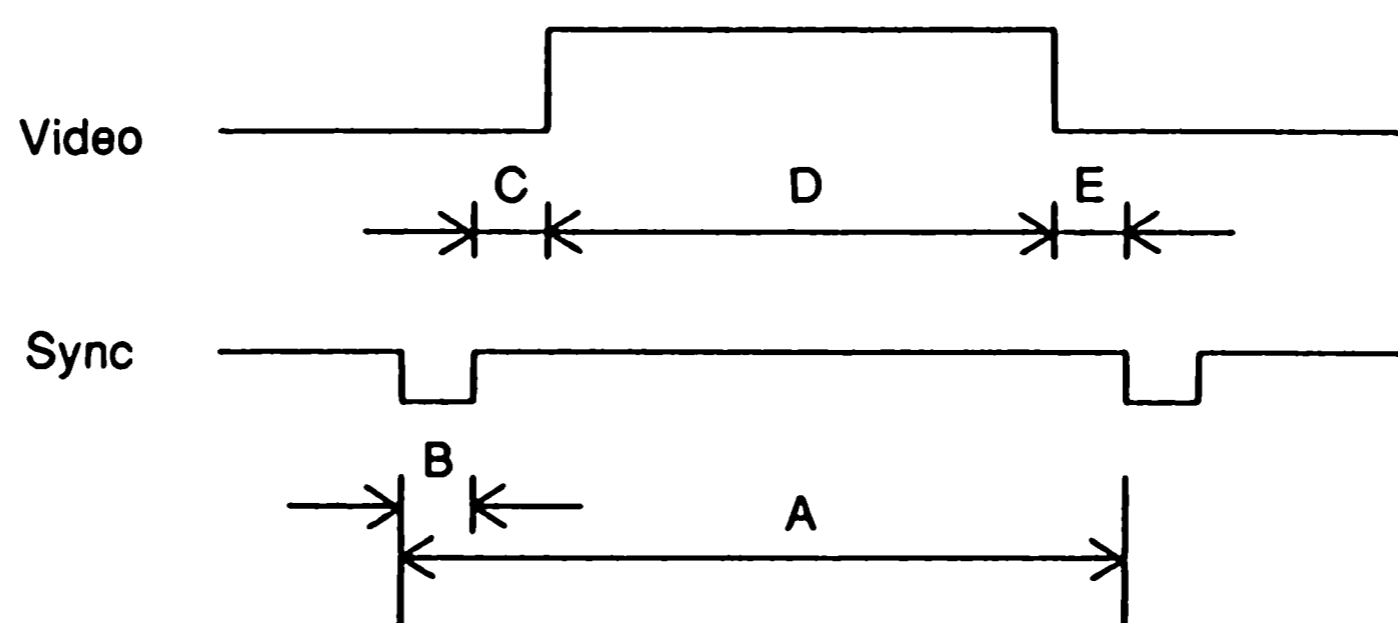

*STEVE
Robinson
R/L Sound*

ADJUSTMENTS PROCEDURES

Signal Name		A	B	C	D	E	Sync Polarity	SCAN SELECT
VIDEO (NTSC)	H (μ s)						SYNC ON VIDEO	OVER
	V (ms)							
VIDEO (PAL)	H (μ s)						SYNC ON VIDEO	OVER
	V (ms)							
VGA1 350 line	H (μ s)	31.778	3.813	1.589	26.058	0.318	+	UNDER
	V (ms)	14.268	0.064	1.716	11.504	0.985	-	
VGA2 400 line	H (μ s)	31.778	3.813	1.589	26.058	0.318	-	UNDER
	V (ms)	14.268	0.064	0.89	13.156	0.159	+	
VGA3 480 line	H (μ s)	31.778	3.813	1.589	26.058	0.318	-	UNDER
	V (ms)	16.683	0.064	0.793	15.762	0.064	-	
VESA (72Hz) 640 X 480	H (μ s)	26.413	1.27	4.063	20.317	0.762	-	UNDER
	V (ms)	13.735	0.079	0.740	12.678	0.238	-	
VESA (56Hz) 800 X 600	H (μ s)	28.444	2.0	3.556	22.222	0.667	+	UNDER
	V (ms)	17.778	0.057	0.607	15.84	0.027	+	
VESA (60Hz) 800 X 600	H (μ s)	26.4	3.2	2.2	20.0	1.0	+	UNDER
	V (ms)	16.579	0.106	0.607	15.84	0.026	+	
VESA (72Hz) 800 X 600	H (μ s)	20.8	2.4	1.28	16.0	1.12	+	UNDER
	V (ms)	13.853	0.125	0.478	12.48	0.77	+	
VESA (60Hz) 1024 X 768	H (μ s)	20.677	2.092	2.462	15.754	0.369	-	UNDER
	V (ms)	16.667	0.124	0.6	15.88	0.062	-	
MAC II 13 inch	H (μ s)	28.57	2.12	3.17	22.81	0.18	SYNC ON GREEN	OVER
	V (ms)	15.0	0.09	1.11	13.71	0.09		
MAC II 16 inch	H (μ s)	20.111	1.117	3.910	14.524	0.559	SYNC ON GREEN	OVER
	V (ms)	13.414	0.06	0.784	12.549	0.02		

Note: Use a separate Composite (TTL-) sync scheme for the MAC II input signal. If these signals are supplied for convenience of signal generator, set the No. 1 of DIP SW2 to ON position and save it with the manual SYNC ON GREEN condition.

15. Video D/A Control Setting

- (1) Connect the wire between pin 1 and pin 7 of connector JB on μ COM/V PWB (PWC-3839) [TEST MODE].
- (2) Input the NTSC 1/4 window white signal, terminated at 75Ω .
- (3) Connect your scope probe to the V-CRT B cathode. Use the Remote Control CONTRAST Up/Down buttons and verify that the video white to black swing equals $85V_{p-p}$. If this swing is less than $80V_{p-p}$. Adjust RGB I/O PWB VR872 (SUB BRIGHT) to desired level is attained.
Note: Do NOT use the Remote Control BRIGHT key to perform this step.
- (4) Next, input the NTSC color bar signal.

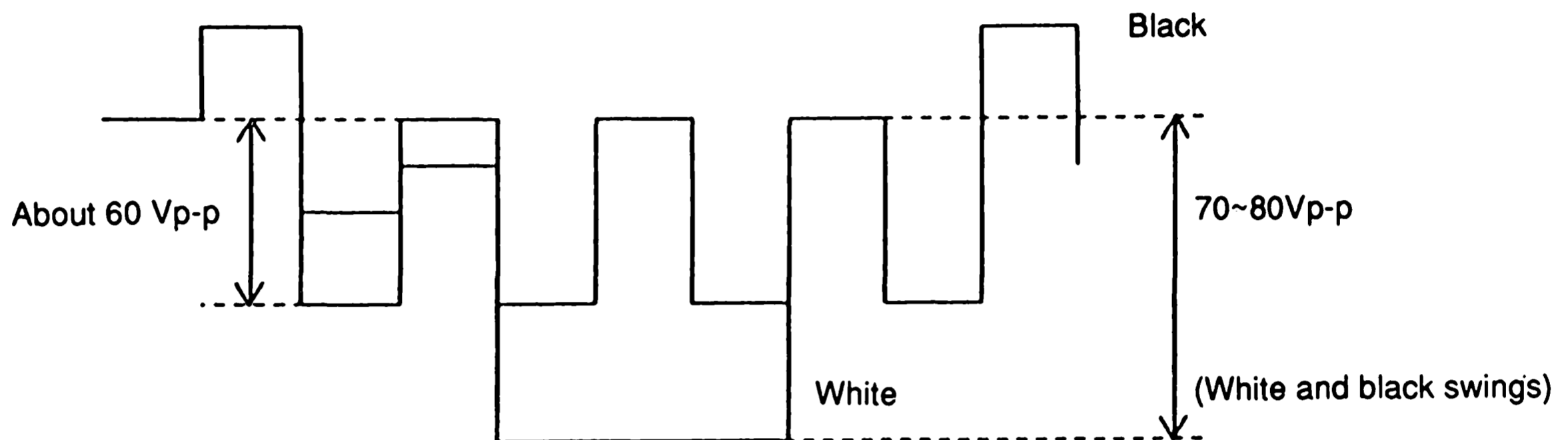

- Note 1:** Do not adjust the CONTRAST key at this point. If you do repeat step (3).
- Note 2:** Set the color waveform so that the voltage is about $60V_{p-p}$ using the COLOR TINT UP/DOWN key of the remote control.
- Note 3:** Do not move the BRIGHT SHARPNESS UP/DOWN key in this condition. If the key is moved by mistake, first set the D/A to the MIN position from the center and set it at No. 32 of the UP direction.
- (5) Now press the Remote Control (Visual Control) NORMAL key to store new data .
Note: When connect the wire between pin 1 and pin 7 of connector JB, NORMAL key (which usually operates as a read function, i. e. preset data read back into user memory) now serves a as write function storing (writing) new data into preset memory area.
 - (6) Repeat Steps (2)~(5) for VIDEO 2 and save data.
 - (7) Input NTSC Split field signal to adjust RGB I/O PWB VR872 (SUB BRIGHT).
 - (8) Set Remote Control CONTRAST to 10 minimum and adjust VR872 so that the bottom right corner of this image is black.
 - (9) Input VGA480 mode 16 level graybar image.
 - (10) Use the Remote Control to maximize (100%) the Contrast setting. Adjust the Brightness Up/Down Setting until the two vertical black vertical stripes adjustment to image become black.
 - (11) Now press the Remote Control (Visual Control) NORMAL key to store this data.
 - (12) Repeat Steps (9)~(11) for RGB2 using the same signal.
 * VR872 (SUB BRIGHT) is common both to Video and RGB input signals.
 - (13) Upon completion of steps (1)~(12) connect the wire between pin 2 and pin 5 of connector JB to universally store this new SUB LEVEL data.
Note: This eliminates the need to input, adjust and store all of the preset signals individually.
 - (14) Now, disconnect the wire between pin 1 and pin 5 of connector JB, and between pin 1 and pin 7 of connector JB to complete the video D/A control setting.

ADJUSTMENTS PROCEDURES

16. Dynamic Focus Waveform Adjustment

- (1) Connect 100 : 1 2pF Probe to the DEF/HV PWB TP5301 (Focus).
- (2) Input VGA3 (480 line mode) crosshatch pattern.
- (3) Adjust the Remote Control Scan Select to UNDERSCAN 95%.
- (4) Set your scope to the 5 mSec time and observe the waveform seen below. Adjust DEF/HV PWB VR5301 (V. Focus ADJ) so that the voltage between points A and B equals $250\pm 20\text{Vpk}$.
- (5) Adjust VR5302 (H. Focus Adj.) of the DEF/HV PWB so that the peak of the waveform of TP5301 (point C of the figure) becomes $1080\pm 20\text{Vpk}$.
- (6) Remove the probe from TP5301.

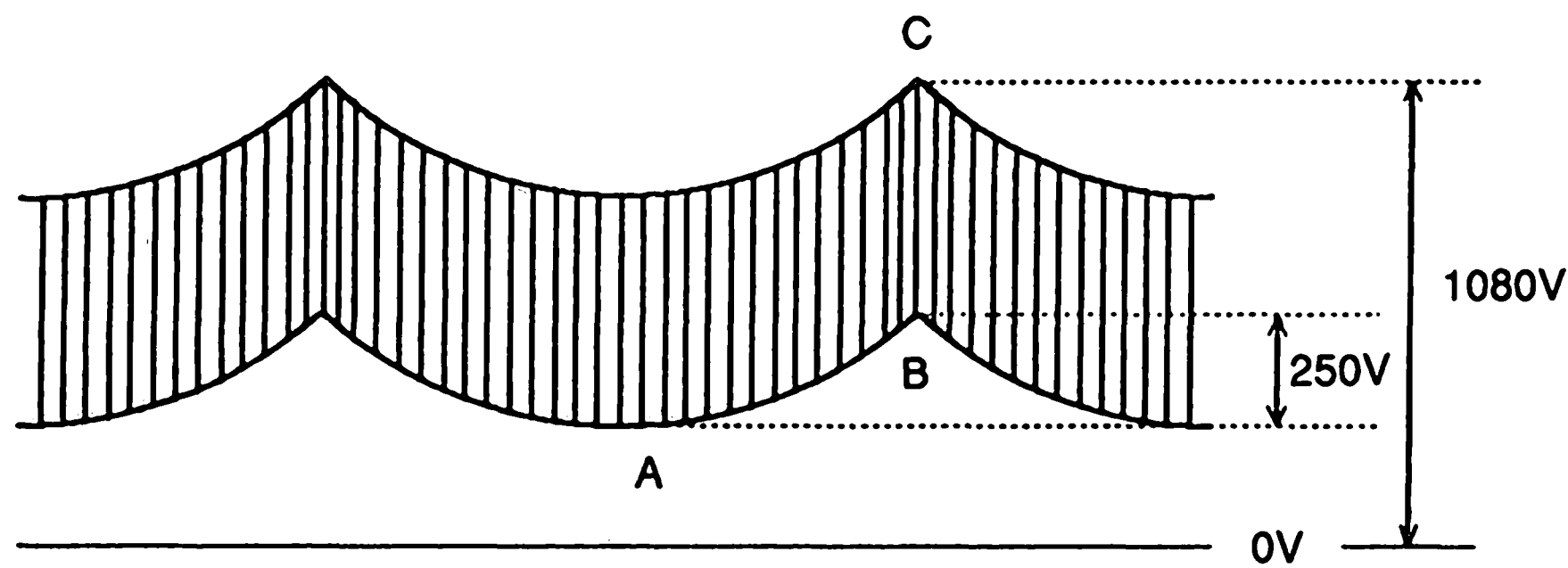

17. Focus Adjustment

- (1) Input a VGA480 inverted crosshatch (black lines on white background).
- (2) Adjust the Remote Control Scan select to UNDERSCAN 95%.
- (3) Set the CONTRAST and BRIGHTNESS in the normal state.
- (4) Set VR901 (VR located to the side of the cooling fan) to the mechanical center.
- (5) Adjust FBT mounted FOCUS1 control for optimum center focus performance.
- (6) Next, Adjust VR901 to balance top and bottom focus performance.

18. High-Voltage Protector Circuit Operation Verification

- (1) Input NTSC split field signal.
- (2) Turn the power off using the remote control.
- (3) Short TP2002 of the DEF/HV PWB with 27 V line (CA of R5117, etc.).
- (4) Press the Remote Control Power Button and verify proper high voltage protect circuit operation as horizontal oscillation has stopped.
- (5) Press the front panel power switch to turn the monitor off Remove the TP2002 $\pm 27\text{V}$ line short. Power back on after 10 seconds and verify normal operation.

CABINET DRAWING

No.	UL	DESCRIPTION	PART CODE	QTY
1	#	CABINET	24D0845	1
2	#	ADHESIVE PIECE A	24F2500	11
3	#	ADHESIVE PIECE B	24F2502	2
4	#	SPECIAL SCREW (M10)	24M0265	2
101	#	FRONT PANEL	2D00643	1
102	#	CRT. MTG. BRKT (TL)	2DH1501	1
103	#	CRT. MTG. BRKT (TR)	2DH1502	1
104	#	CRT. MTG. BRKT (BL)	2DH1503	1
105	#	CRT. MTG. BRKT (BR)	2DH1504	1
106	#	FILTER	24F1838	1
107	#	INDICATOR	24F1848	1
108	#	PUSH BUTTON (POWER)	24GS905	1
109	#	SPRING	24H1470	1
110	#	BACKET (FRONT) A	2DH1487	2
111	#	RUBBER FOOT A	24J0687	2
112	#	CUSHION SHEET	24J0737	2
113	#	SHEET (FRONT)	24J0744	2
201	#	2CBRTS 416 158F (6)	91664061	26

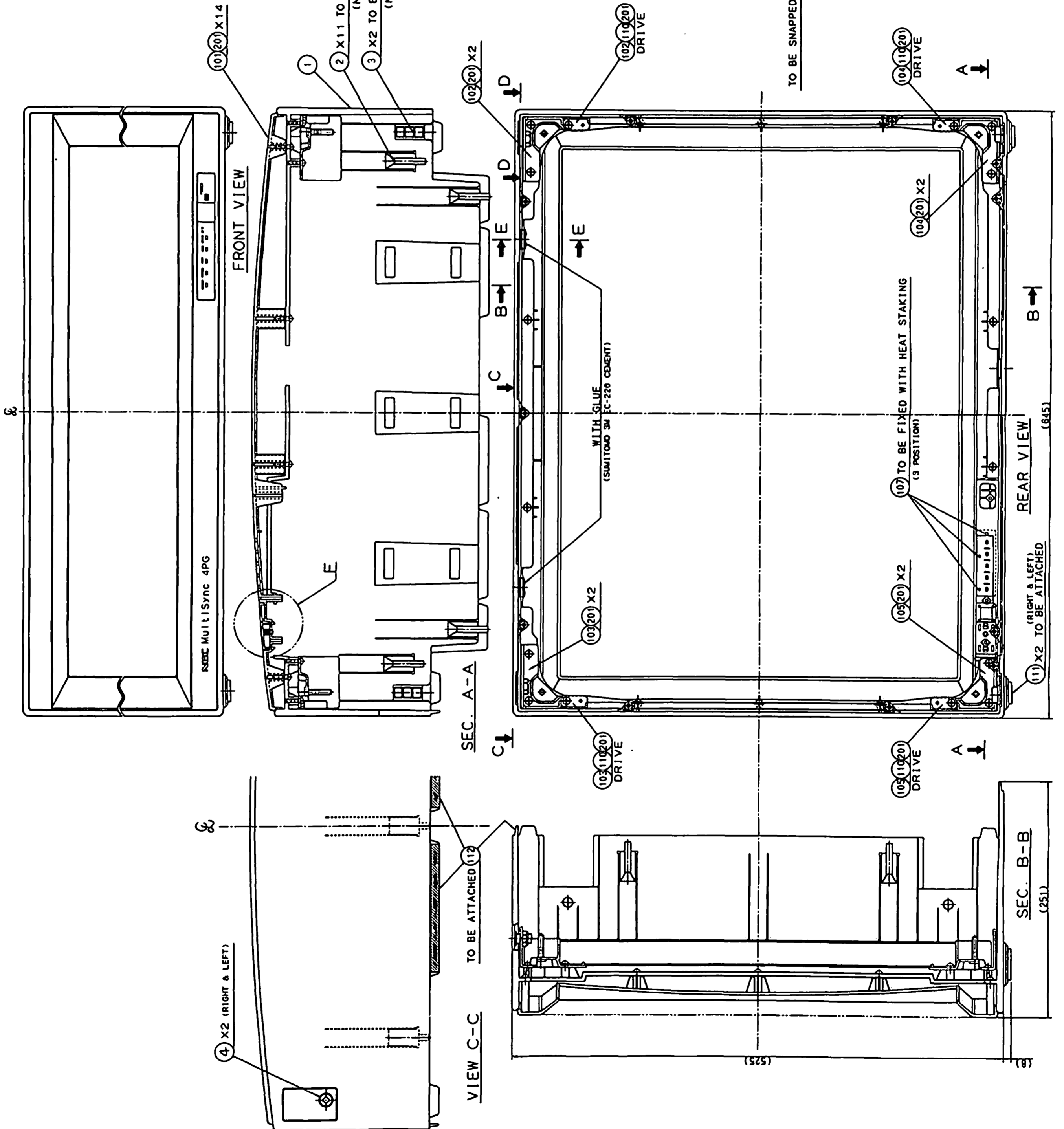

CABINET DRAWING

No.	UL	DESCRIPTION	PART CODE	QTY
1	#	CABINET BACK	24D0846	1
2	#	HANDLE A (TOP)	24F2472	2
3	#	HANDLE A (BOTTOM)	24F2473	2
4	#	HANDLE B (TOP)	24F2480	2
5	#	HANDLE B (BOTTOM)	24F2481	2
6	#	BRACKET HANDLE A	24H2071	4
8	#	BRACKET C	24H2085	1
9	#	BRACKET D	24H2086	1
10	#	RUBBER FOOT B	24J1039	2
11	#	ADHESIVE PIECE B	24F2601	2
12	#	CARRY GRIP A	24F2503	2
13	#	CARRY GRIP B	24F2604	2
101		BRACKET (CARRY) TL	2DH1468	1
102		BRACKET (CARRY) TR	2DH1651	1
103	#	CUSHION SHEET (PART 70.3)	24J0738	4
201		SCREW, #10x16x16x3/8	91824066	12
202		SCREW, FT14x26x15BF	2485206	6
203		SCREW, FT14x20x15BF	2485174	8
204		SCREW, FT14x18x15BF	2485173	4

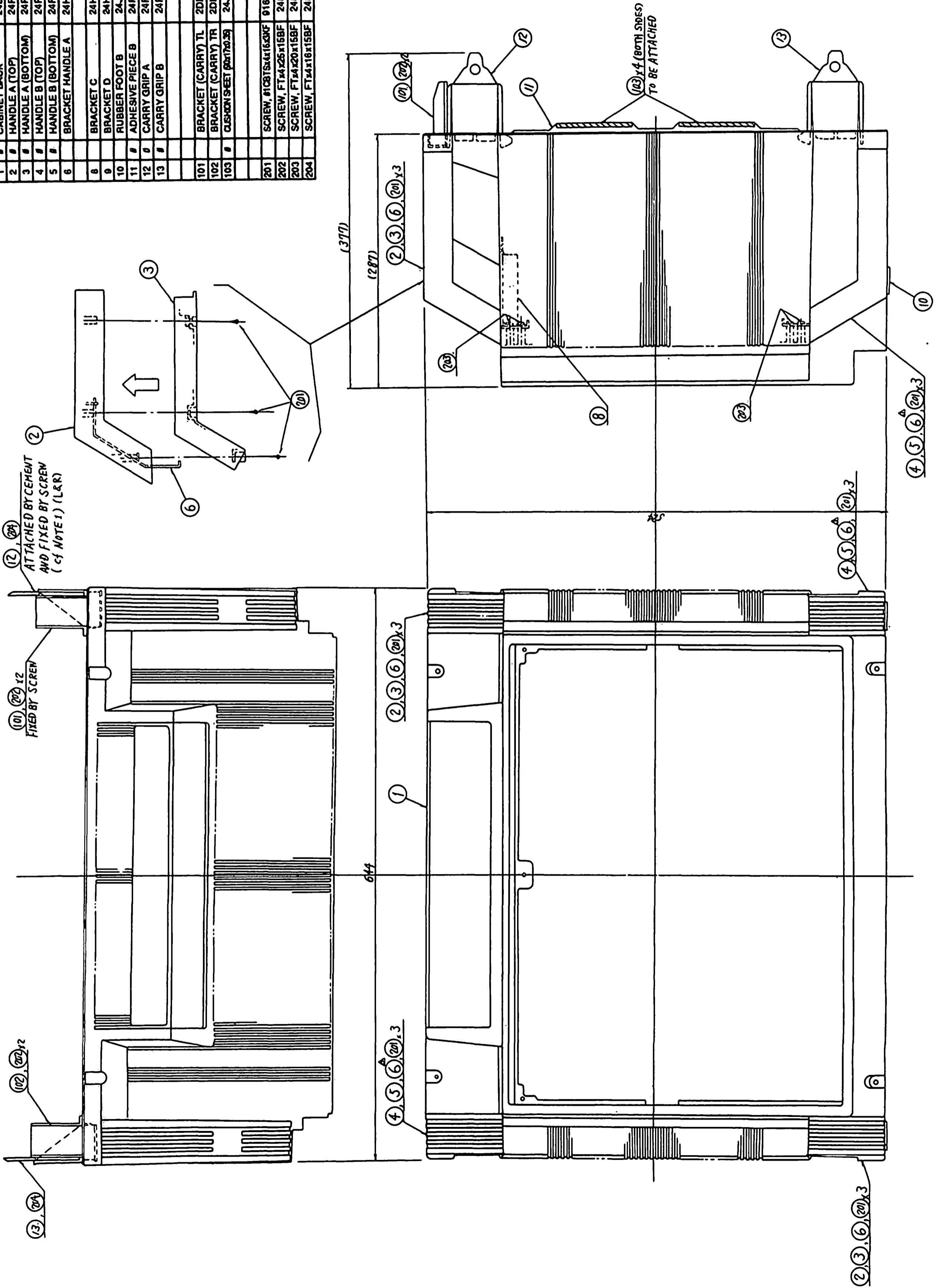

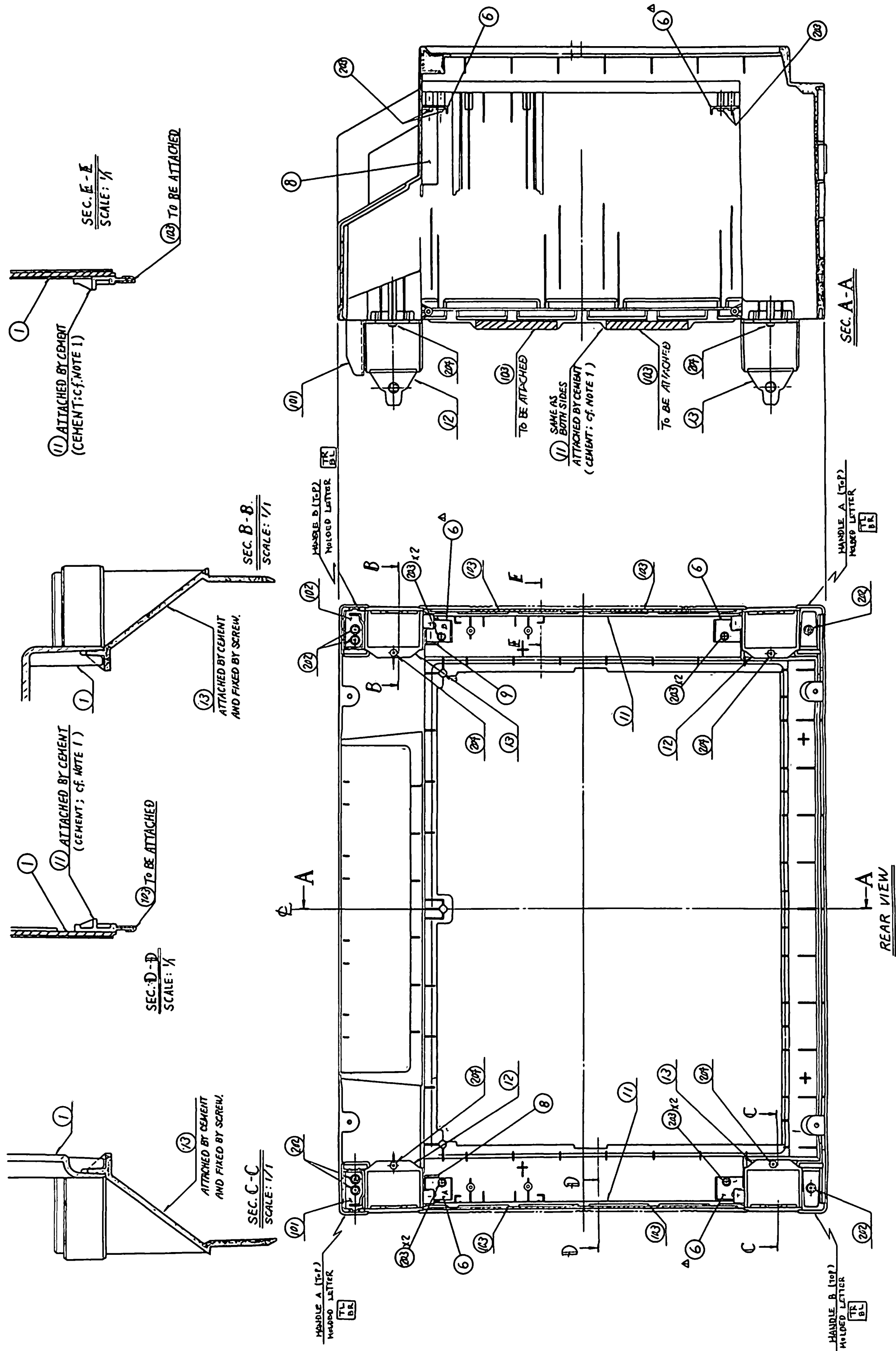

PACKAGING

Disposal of Serial Number Label (24L2948[])

Please peel off and put on registration cards in appropriate place.	Ⓐ	Model No. <input type="checkbox"/> <input type="checkbox"/> <input type="checkbox"/> Serial No. <input type="checkbox"/> <input type="checkbox"/> <input type="checkbox"/> Description <input type="checkbox"/> <input type="checkbox"/> <input type="checkbox"/>	Ⓑ	Model No. <input type="checkbox"/> <input type="checkbox"/> <input type="checkbox"/> Serial No. <input type="checkbox"/> <input type="checkbox"/> <input type="checkbox"/> Description <input type="checkbox"/> <input type="checkbox"/> <input type="checkbox"/>	Ⓒ	Model No. <input type="checkbox"/> <input type="checkbox"/> <input type="checkbox"/> Serial No. <input type="checkbox"/> <input type="checkbox"/> <input type="checkbox"/> Description <input type="checkbox"/> <input type="checkbox"/> <input type="checkbox"/>	Ⓓ	NEC <input checked="" type="checkbox"/> <input checked="" type="checkbox"/> <input checked="" type="checkbox"/> Model No. <input type="checkbox"/> <input type="checkbox"/> <input type="checkbox"/> Manufactured <input type="checkbox"/> <input type="checkbox"/> <input type="checkbox"/> Serial No. <input type="checkbox"/> <input type="checkbox"/> <input type="checkbox"/>
	ⓑ	Model No. <input type="checkbox"/> <input type="checkbox"/> <input type="checkbox"/> Serial No. <input type="checkbox"/> <input type="checkbox"/> <input type="checkbox"/> Description <input type="checkbox"/> <input type="checkbox"/> <input type="checkbox"/>	Ⓔ	BRAND NAME NEC <input checked="" type="checkbox"/> <input checked="" type="checkbox"/> <input checked="" type="checkbox"/> NEC Technologies, Inc. Model No. <input type="checkbox"/> <input type="checkbox"/> <input type="checkbox"/> 1255 Michael Drive Serial No. <input type="checkbox"/> <input type="checkbox"/> <input type="checkbox"/> Wood Dale, Illinois 60191-1094	ⓓ	BRAND NAME NEC <input checked="" type="checkbox"/> <input checked="" type="checkbox"/> <input checked="" type="checkbox"/> NEC Technologies, Inc. Model No. <input type="checkbox"/> <input type="checkbox"/> <input type="checkbox"/> 1255 Michael Drive Serial No. <input type="checkbox"/> <input type="checkbox"/> <input type="checkbox"/> Wood Dale, Illinois 60191-1094	ⓔ	BRAND NAME NEC <input checked="" type="checkbox"/> <input checked="" type="checkbox"/> <input checked="" type="checkbox"/> NEC Technologies, Inc. Model No. <input type="checkbox"/> <input type="checkbox"/> <input type="checkbox"/> 1255 Michael Drive Serial No. <input type="checkbox"/> <input type="checkbox"/> <input type="checkbox"/> Wood Dale, Illinois 60191-1094
	Ⓒ	Model No. <input type="checkbox"/> <input type="checkbox"/> <input type="checkbox"/> Serial No. <input type="checkbox"/> <input type="checkbox"/> <input type="checkbox"/> Description <input type="checkbox"/> <input type="checkbox"/> <input type="checkbox"/>	ⓕ	BRAND NAME NEC <input checked="" type="checkbox"/> <input checked="" type="checkbox"/> <input checked="" type="checkbox"/> NEC Technologies, Inc. Model No. <input type="checkbox"/> <input type="checkbox"/> <input type="checkbox"/> 1255 Michael Drive Serial No. <input type="checkbox"/> <input type="checkbox"/> <input type="checkbox"/> Wood Dale, Illinois 60191-1094	ⓖ	BRAND NAME NEC <input checked="" type="checkbox"/> <input checked="" type="checkbox"/> <input checked="" type="checkbox"/> NEC Technologies, Inc. Model No. <input type="checkbox"/> <input type="checkbox"/> <input type="checkbox"/> 1255 Michael Drive Serial No. <input type="checkbox"/> <input type="checkbox"/> <input type="checkbox"/> Wood Dale, Illinois 60191-1094	ⓗ	BRAND NAME NEC <input checked="" type="checkbox"/> <input checked="" type="checkbox"/> <input checked="" type="checkbox"/> NEC Technologies, Inc. Model No. <input type="checkbox"/> <input type="checkbox"/> <input type="checkbox"/> 1255 Michael Drive Serial No. <input type="checkbox"/> <input type="checkbox"/> <input type="checkbox"/> Wood Dale, Illinois 60191-1094
	Ⓓ	Model No. <input type="checkbox"/> <input type="checkbox"/> <input type="checkbox"/> Serial No. <input type="checkbox"/> <input type="checkbox"/> <input type="checkbox"/> Description <input type="checkbox"/> <input type="checkbox"/> <input type="checkbox"/>	ⓙ	BRAND NAME NEC <input checked="" type="checkbox"/> <input checked="" type="checkbox"/> <input checked="" type="checkbox"/> NEC Technologies, Inc. Model No. <input type="checkbox"/> <input type="checkbox"/> <input type="checkbox"/> 1255 Michael Drive Serial No. <input type="checkbox"/> <input type="checkbox"/> <input type="checkbox"/> Wood Dale, Illinois 60191-1094	24L2948/	ⓓ	BRAND NAME NEC <input checked="" type="checkbox"/> <input checked="" type="checkbox"/> <input checked="" type="checkbox"/> NEC Technologies, Inc. Model No. <input type="checkbox"/> <input type="checkbox"/> <input type="checkbox"/> 1255 Michael Drive Serial No. <input type="checkbox"/> <input type="checkbox"/> <input type="checkbox"/> Wood Dale, Illinois 60191-1094	ⓔ

A) Display Contents and Display Points

The specified display of Model No., serial No., Description, date code, and factory ID shall be automatically printed (marked).

Example:	Model No.	PG-2740	(<input type="checkbox"/> <input type="checkbox"/> <input type="checkbox"/> section)	13 points
	Serial No.	00000000	(<input type="checkbox"/> <input type="checkbox"/> <input type="checkbox"/> section)	13 points
	Description	"27" data monitor	(<input checked="" type="checkbox"/> <input checked="" type="checkbox"/> <input checked="" type="checkbox"/> section)	6 points
	Date code		(<input type="checkbox"/> <input type="checkbox"/> <input type="checkbox"/> section)	1 point
	Factory ID	720K	(<input checked="" type="checkbox"/> <input checked="" type="checkbox"/> <input checked="" type="checkbox"/> section)	3 points
		* 720K		Production at the Odawara Factory





































* The labels not used may not be printed.
(Example: Ⓔ and ⓕ)

B) Display Contents Specifying

This shall be specified by the Production

C) Sealing Places

Please peel off and put on registration cards in appropriate place.







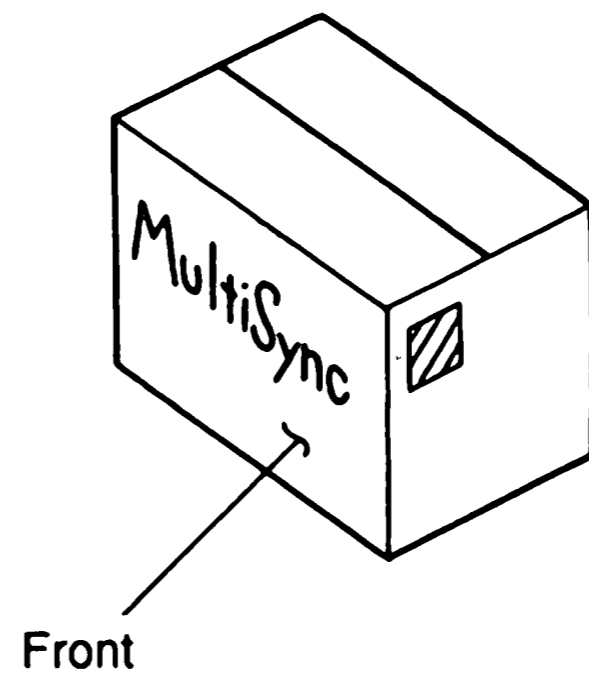

<input type="checkbox"/>	Model No.    [Ⓐ]
	Serial No.   
	Description   
	Model No.    [Ⓑ]
	Serial No.   
	Description   
	Model No.    [Ⓒ]
	Serial No.   
	Description   
	Model No.    [Ⓓ]
	Serial No.   
	Description   

Cut the left section together with the cardboard paper, insert it in the polyethylene bag (DHHS) (24M0291[]) together with the DHH card (24L2949[]), and put it at the specified point on the right top on the left side of the cardboard. In this case, sealing shall be made in such a position where the model No., Serial No., and description can be seen.

[Each dealer should apply the label shown at left upon the [] marked points Ⓐ, Ⓑ, and Ⓒ of the DHHS card by removing the labels Ⓐ, Ⓑ, and Ⓒ.]



D) Application to Terminal Fitting Strip

NEC	Model No. ^①
Date Code.	  
  	Serial No.
	  

Remove the left shown at left from the cardboard and apply it to the lower left (the lower section of the IUL back nameplate) of the terminal fitting strip (R) of each set.

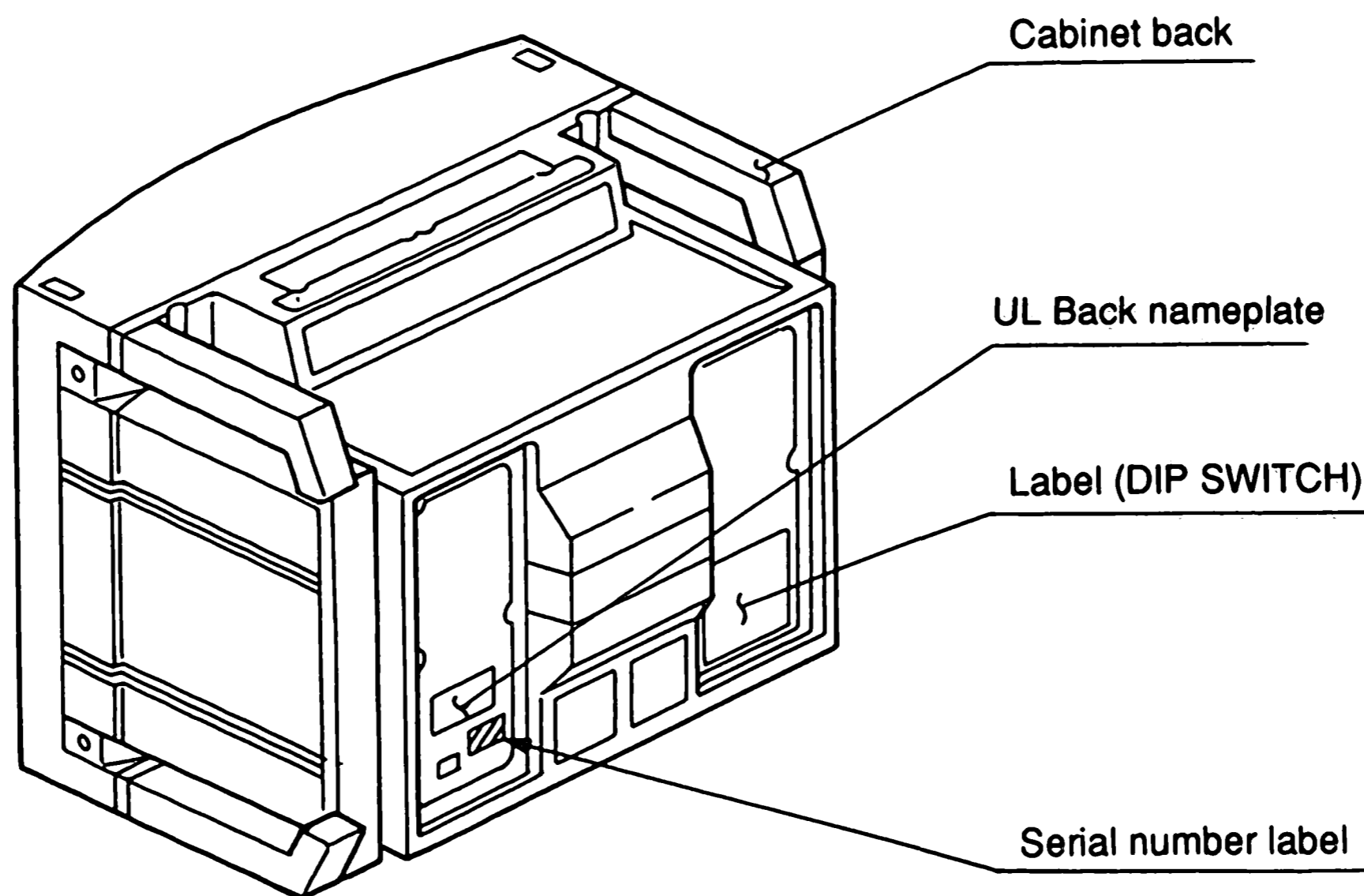

PACKAGING

E) Application to the Cardboard Box

E-1) Right Side

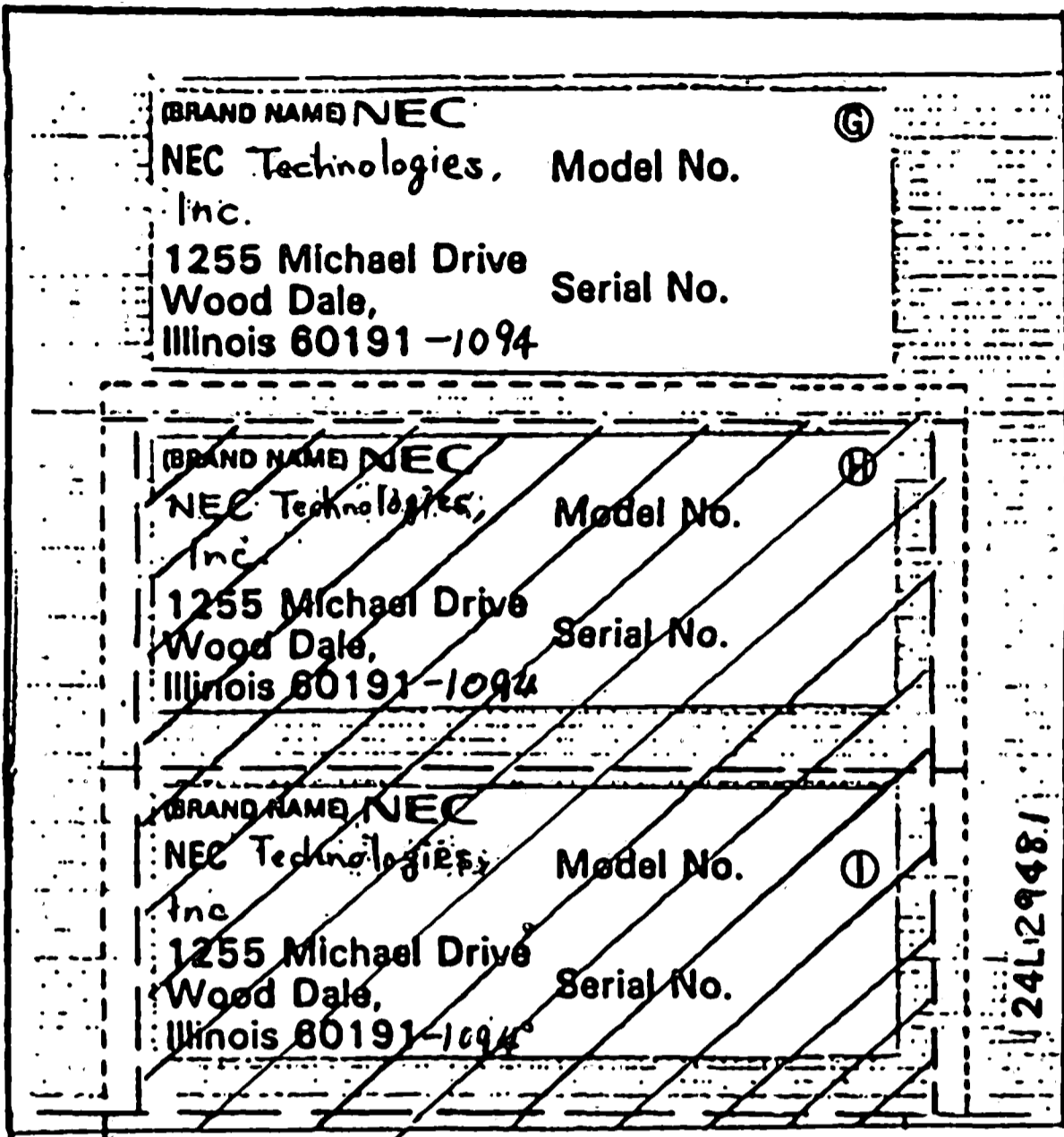

Remove the label shown at left from the cardboard and apply it to the left top on the left of the cardboard. (However, the cardback of the broken line portion shown at left must be applied by not removing it.)

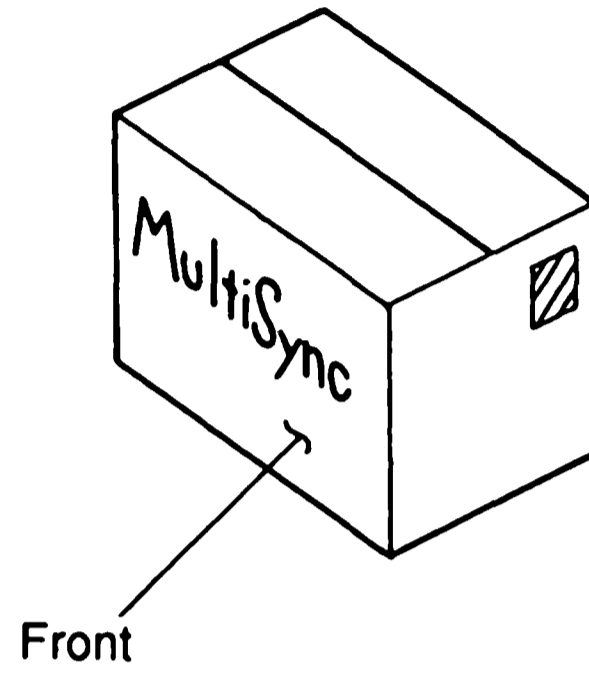

E-2) Left Side

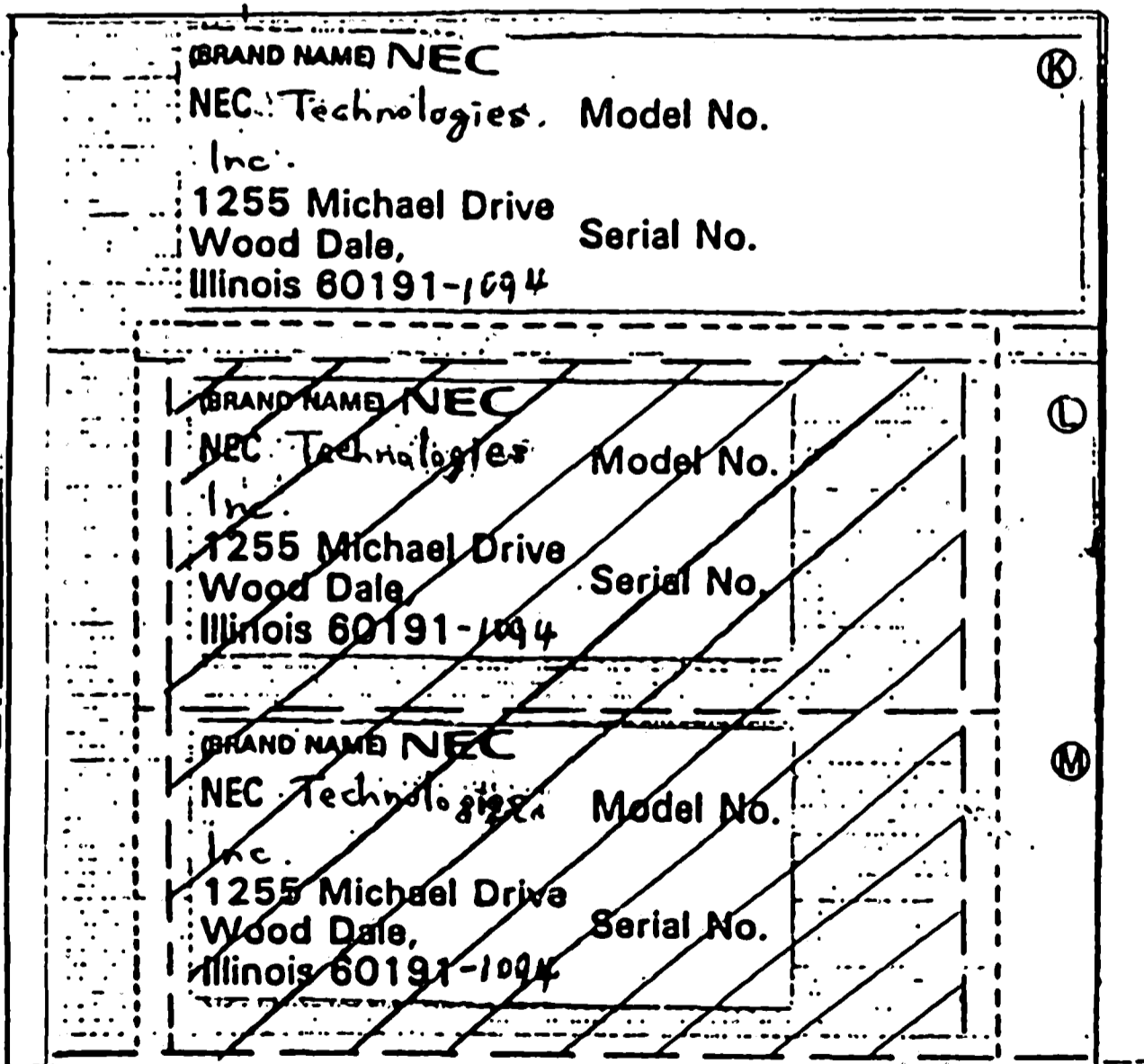

Remove the label shown at left from the cardboard and apply it to the right top on the left side of the cardboard. (But apply the label without removing the cardboard of the broken line shown at left.)

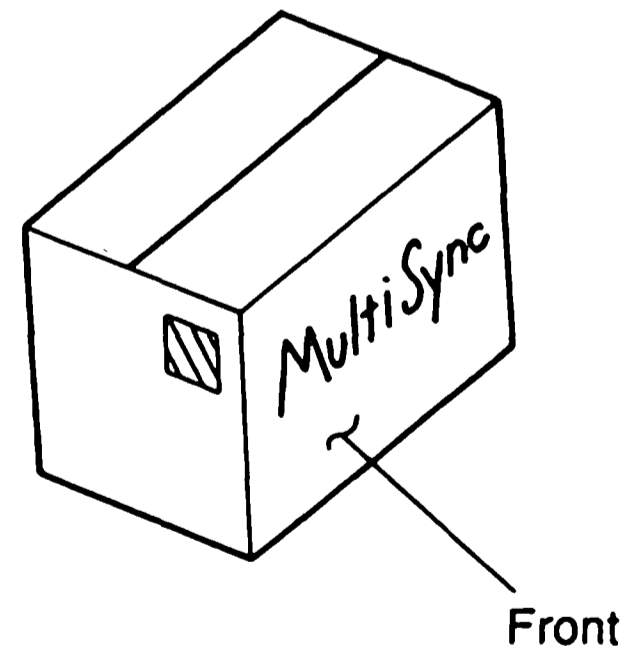

Disposal of Polyethylene Bag (DHHS) (24M0291[])

Insert the (A), (B), (C), and (D) sections (with the cardboard) of the DHHS card (24L2949[]) and the serial number label (24L2948[]) inside, fold the top end section of the polyethylene bag (DHHS), seal it, and remove the back cardboard. Then, apply the label to the right top on the right side of the cardboard with it laid to the right.

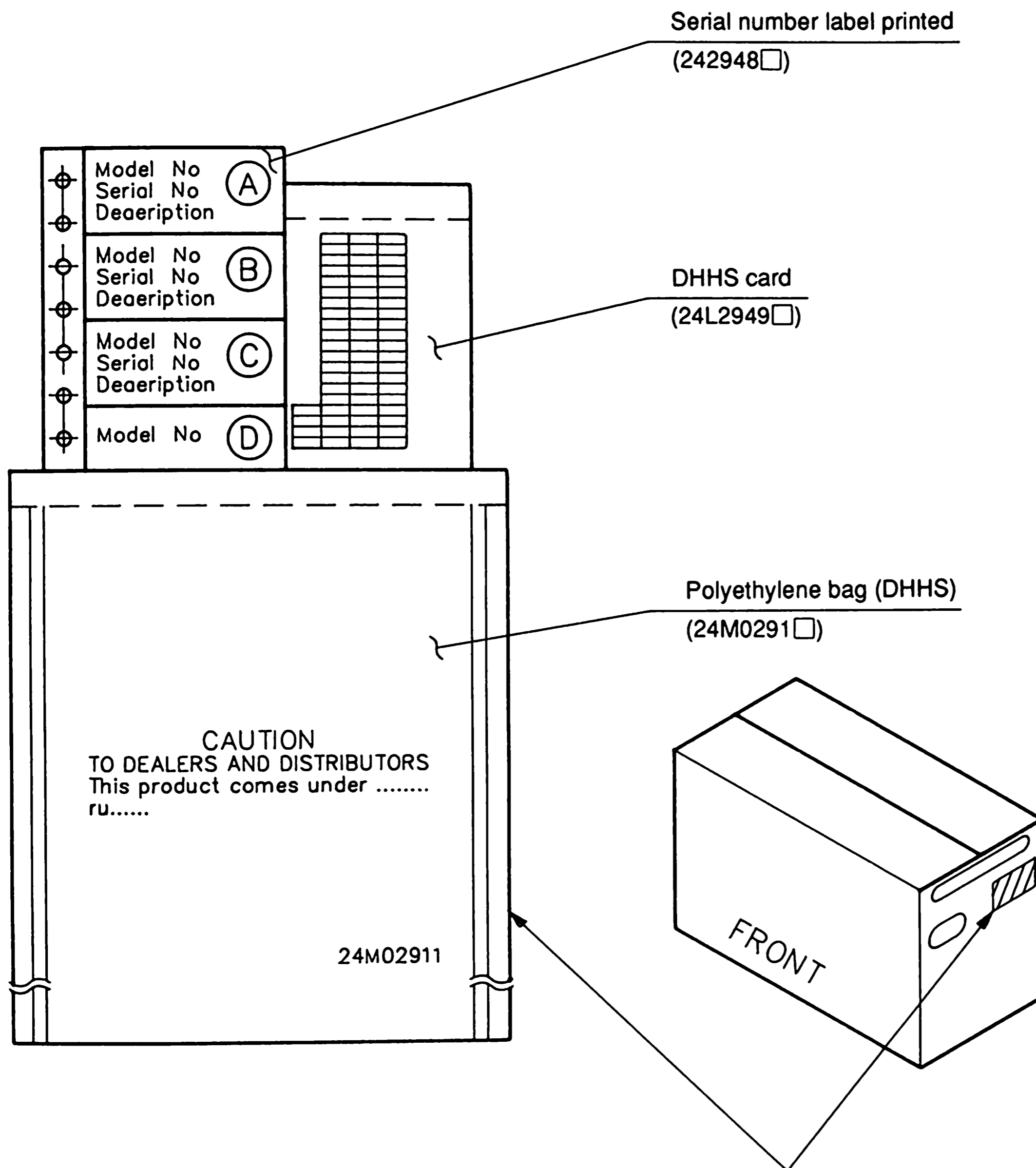

Apply the label with it right to the right.

PACKAGING

Service bag ass'y:

Bag polyethylene	(24806961)
Battery SUM-3	(68043001)
Plug, Cable (4M)	(73499229)
Registration Card	(78046212)
User's Manual	(78405011)
Remote Controller	(7964-2701)

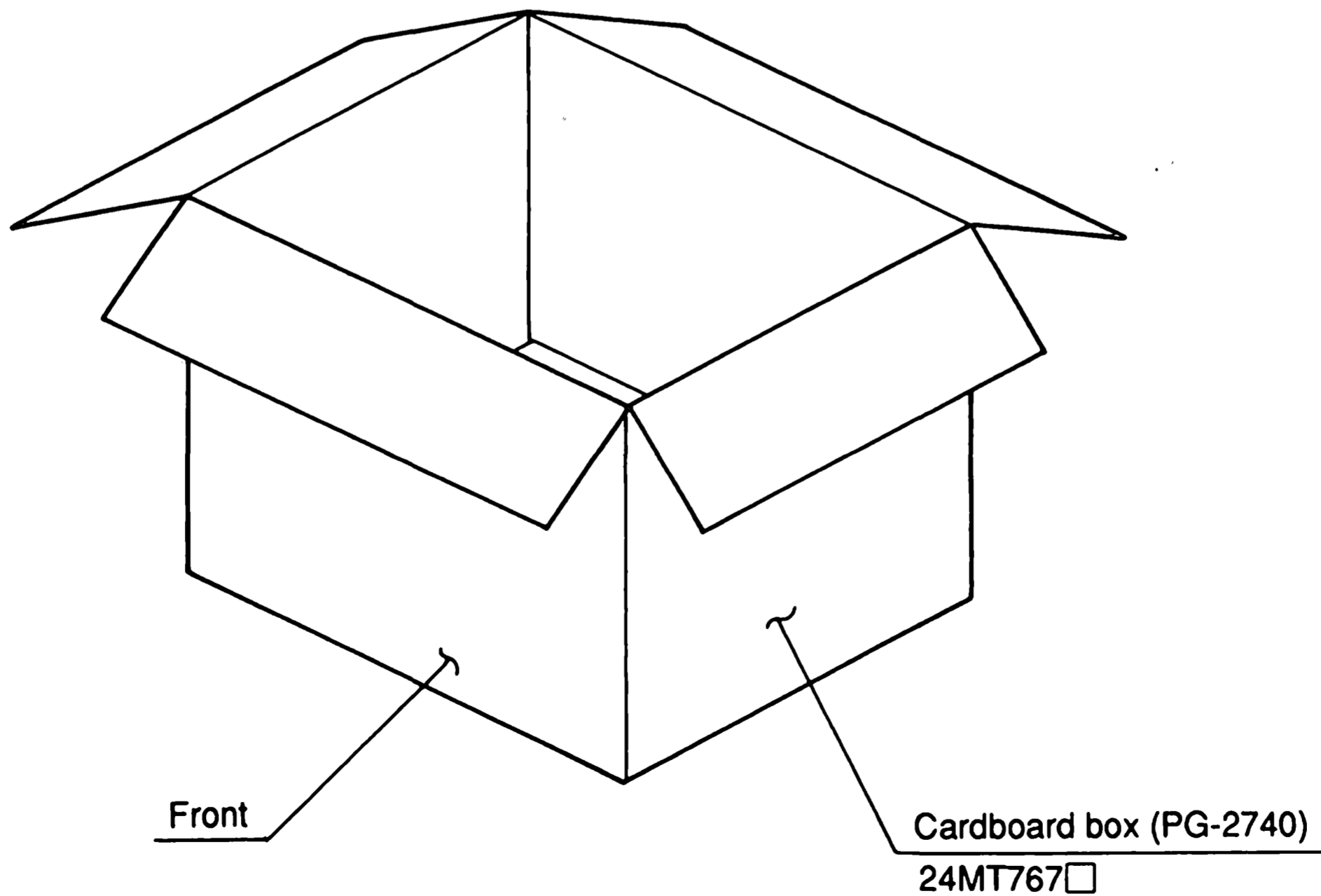
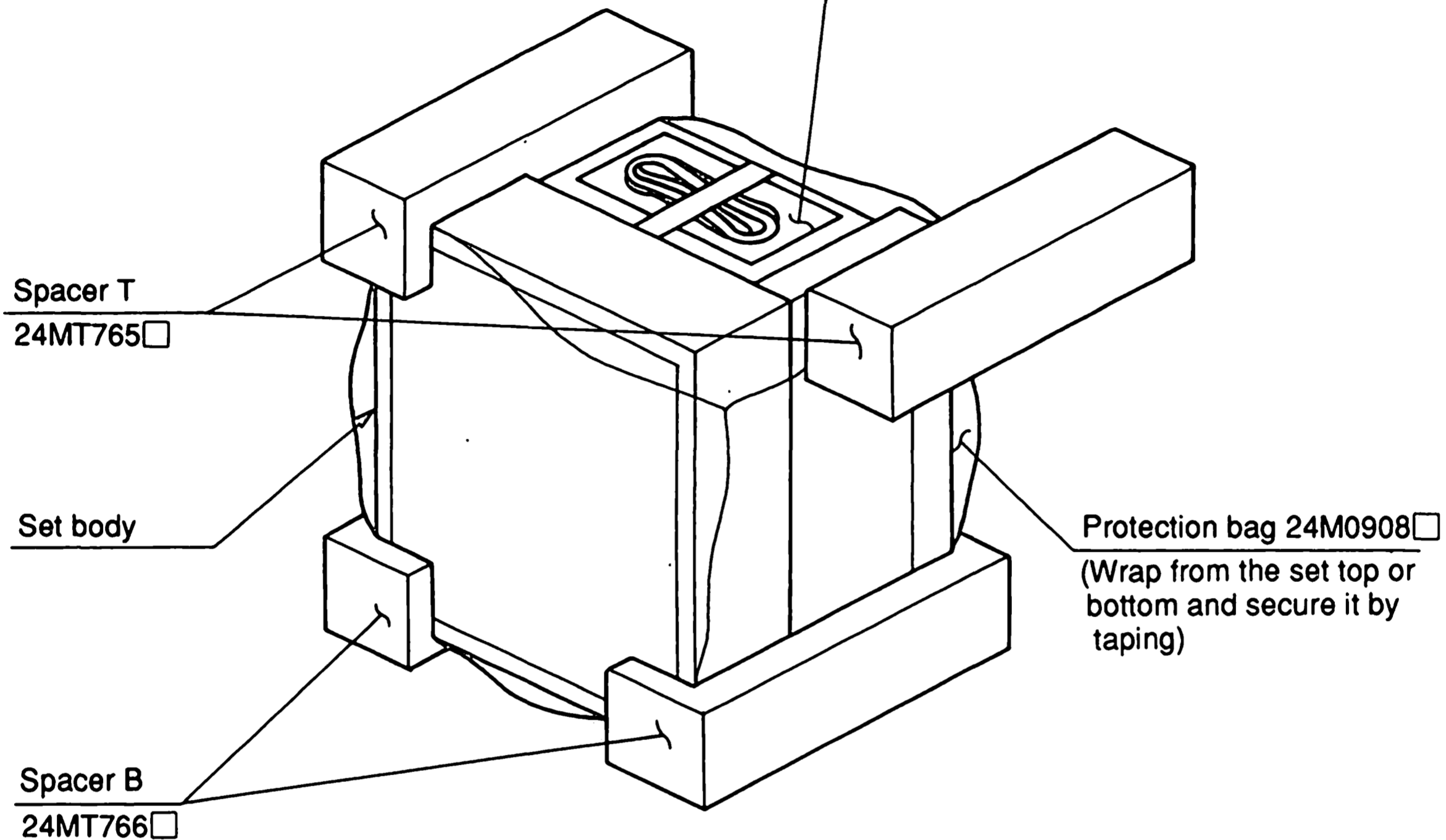

Print as shown below on the bar code serial label (1676179) and apply it to the back of the cardboard.

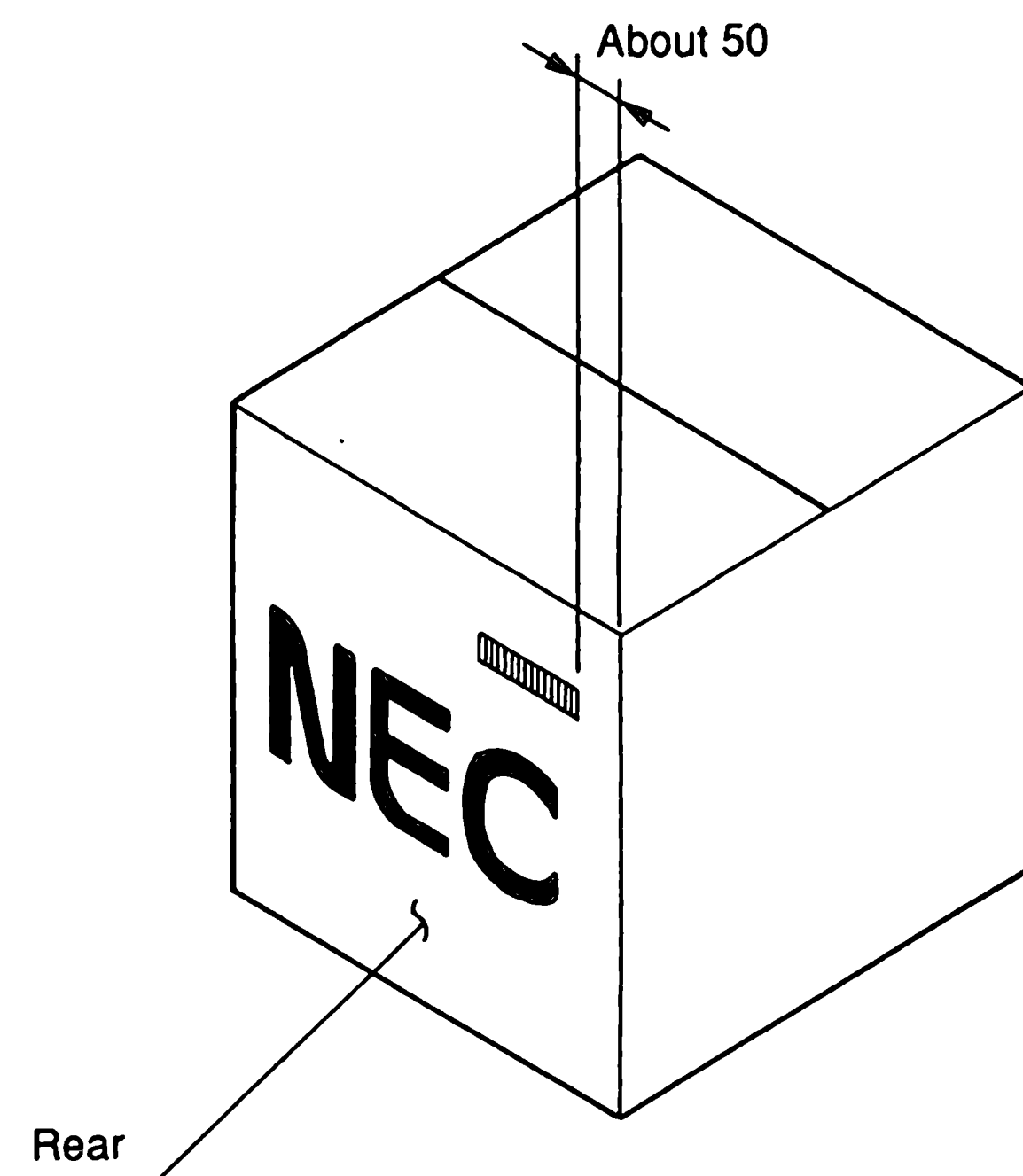
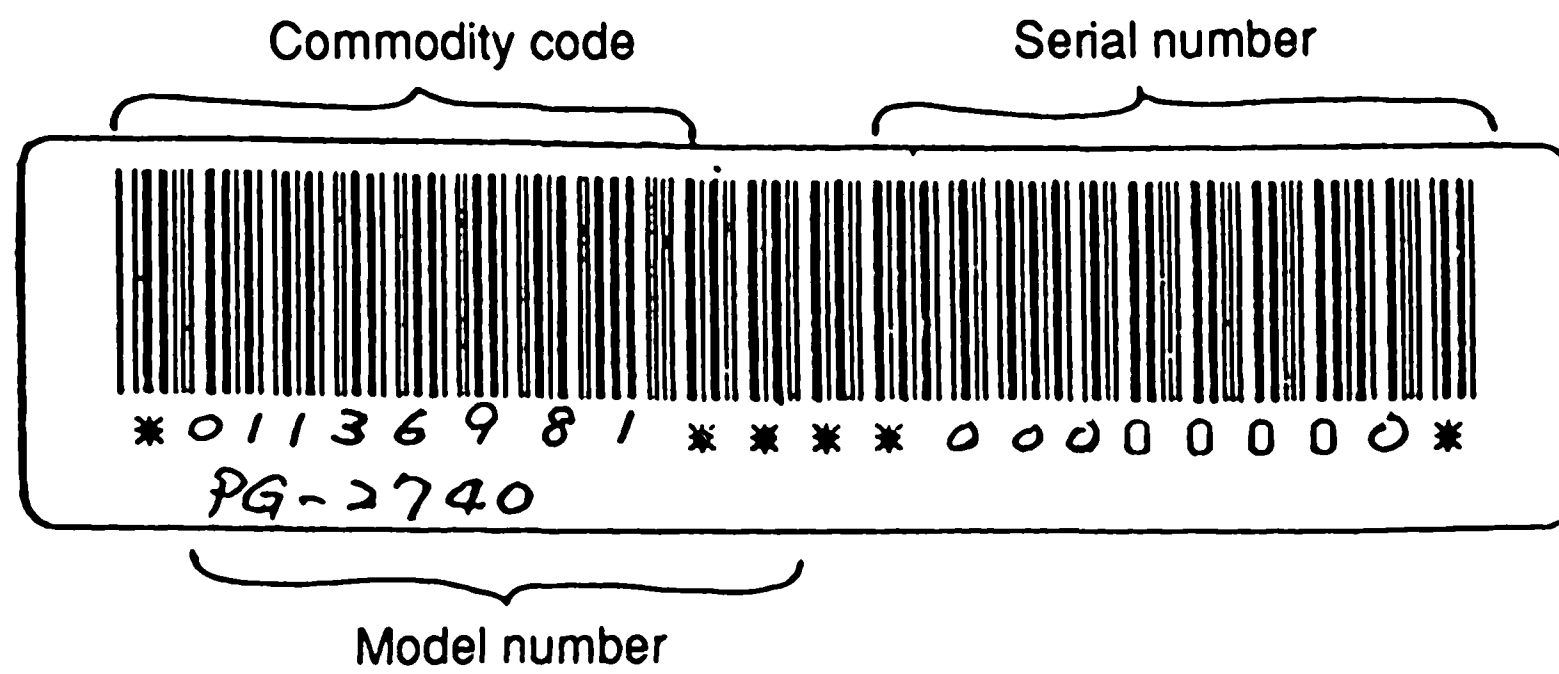

CONNECTION DIAGRAM

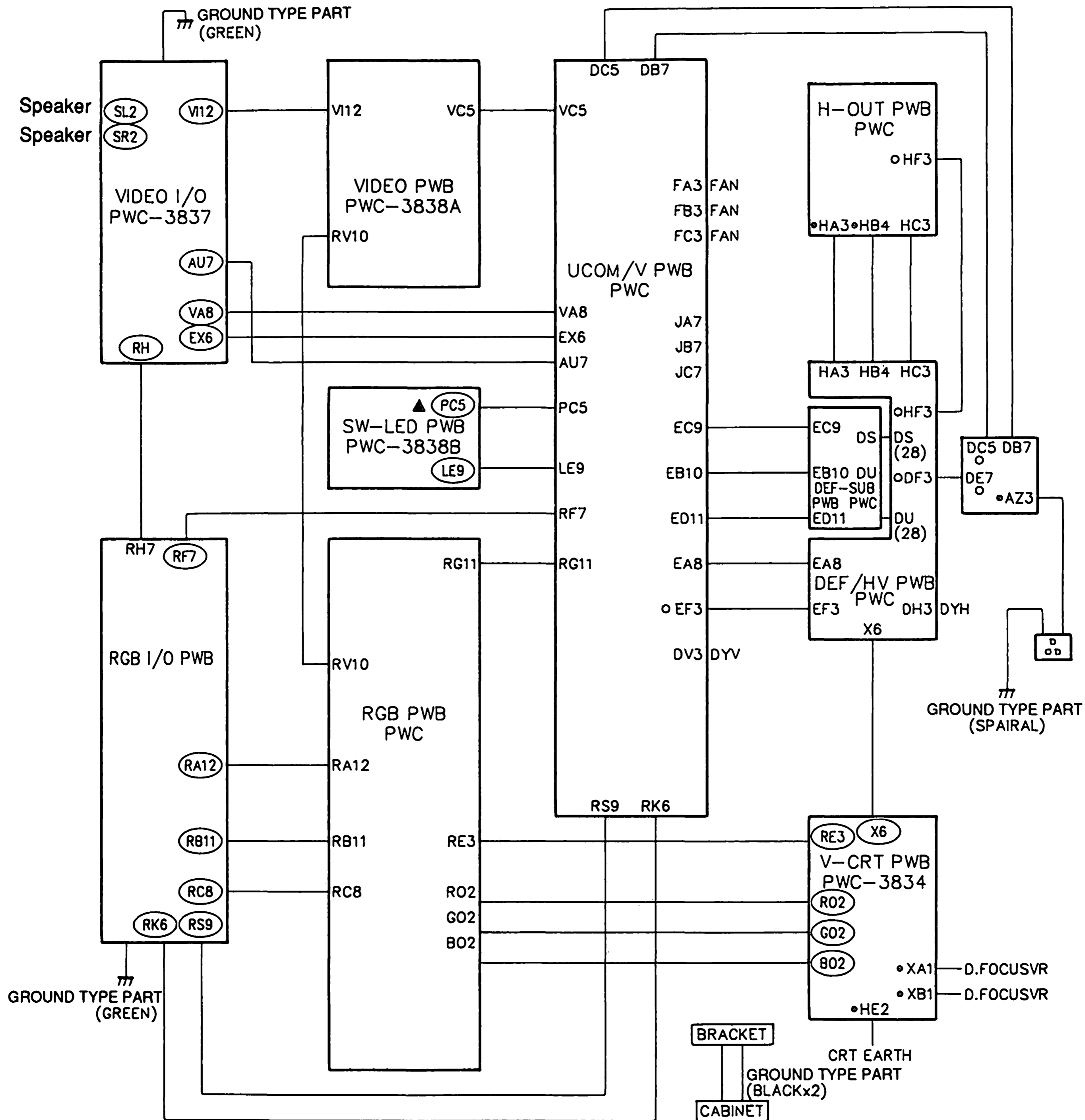

- : BOARD IN CONNECTOR
- : OCTAL CONNECTOR
- : MINI CONNECTOR
- ◡ : EH CONNECTOR
- ▲ : TLB CONNECTOR

BLOCK DIAGRAM

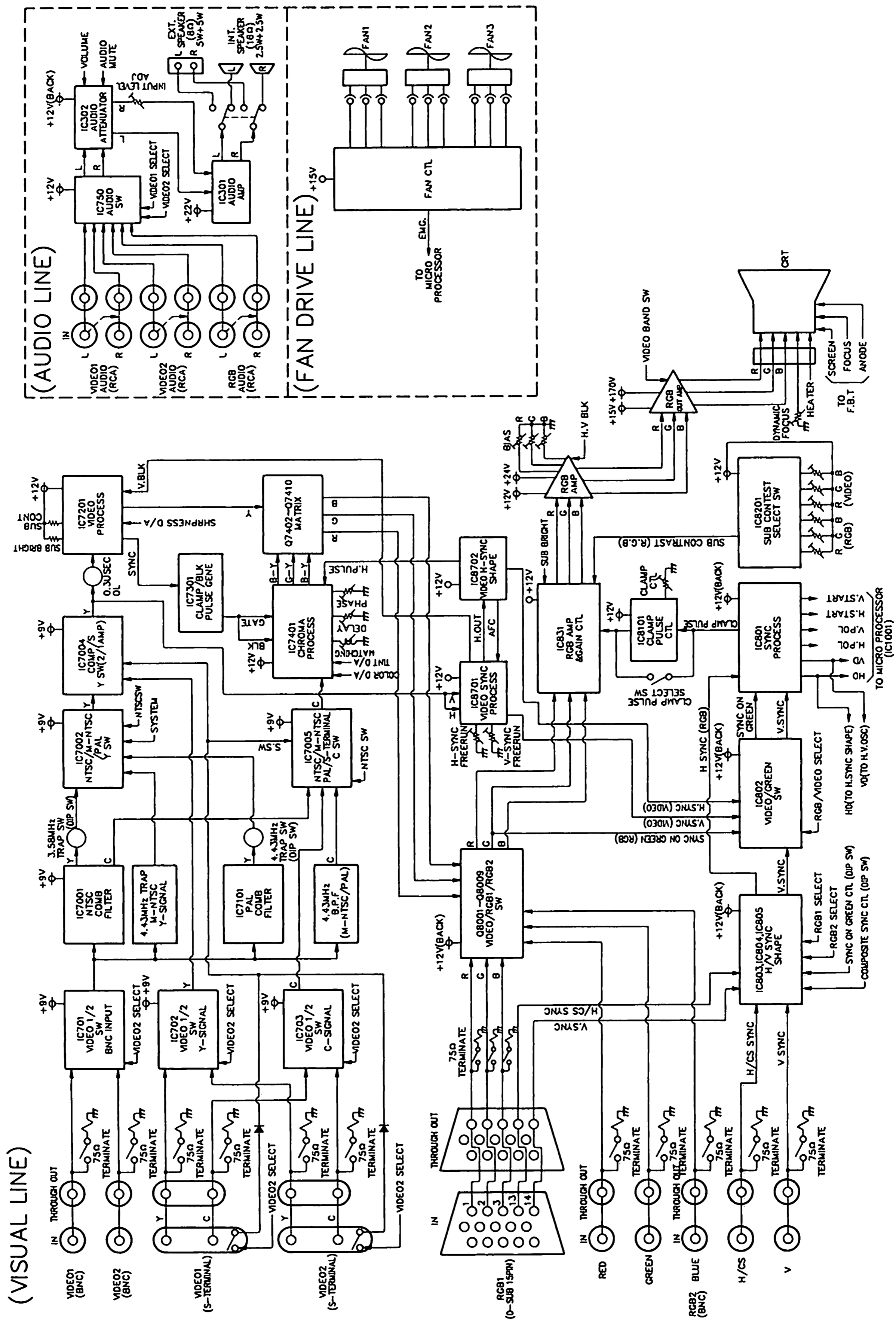

BLOCK DIAGRAM

(DEFLECTION, HIGH VOLTAGE LINE)

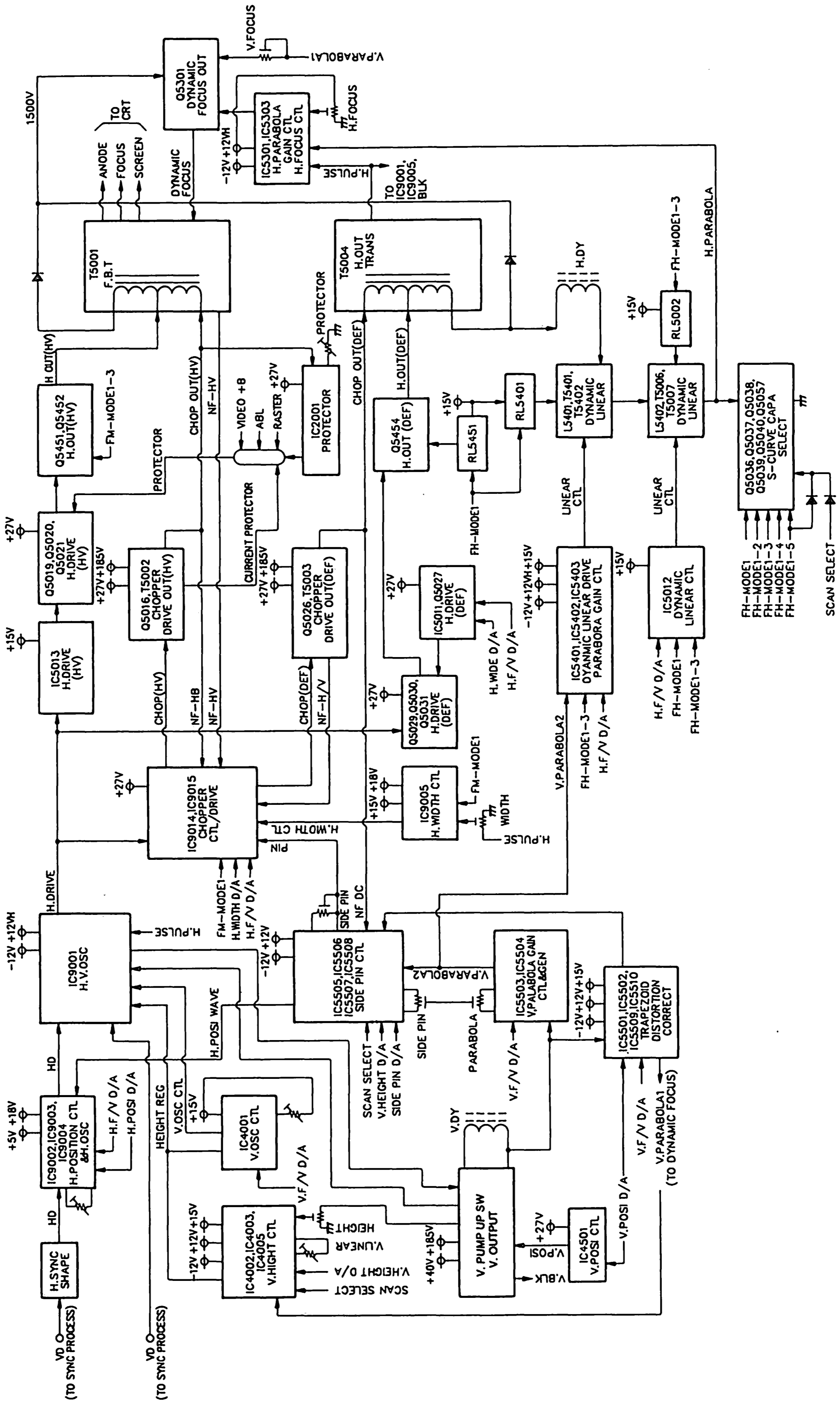

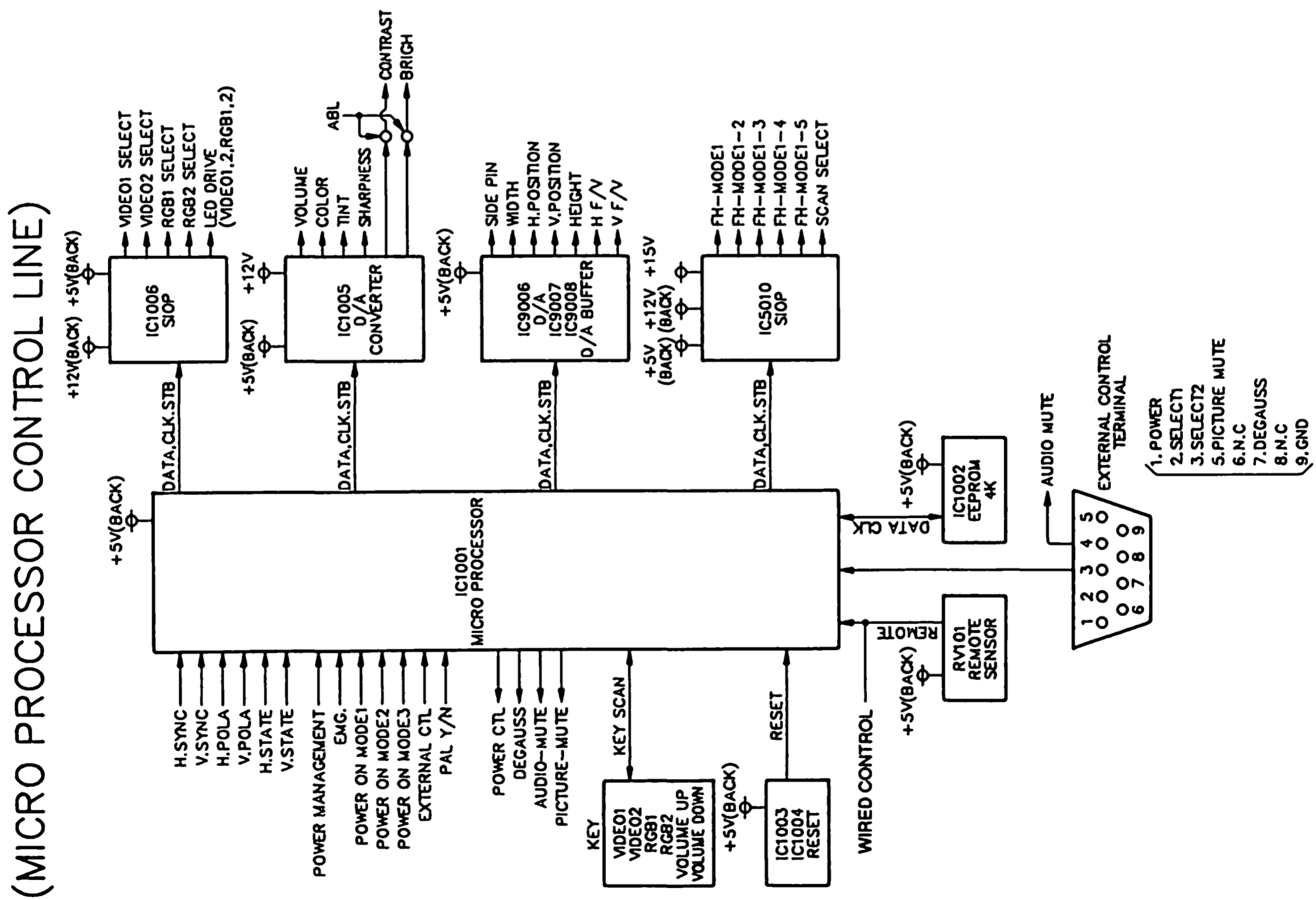
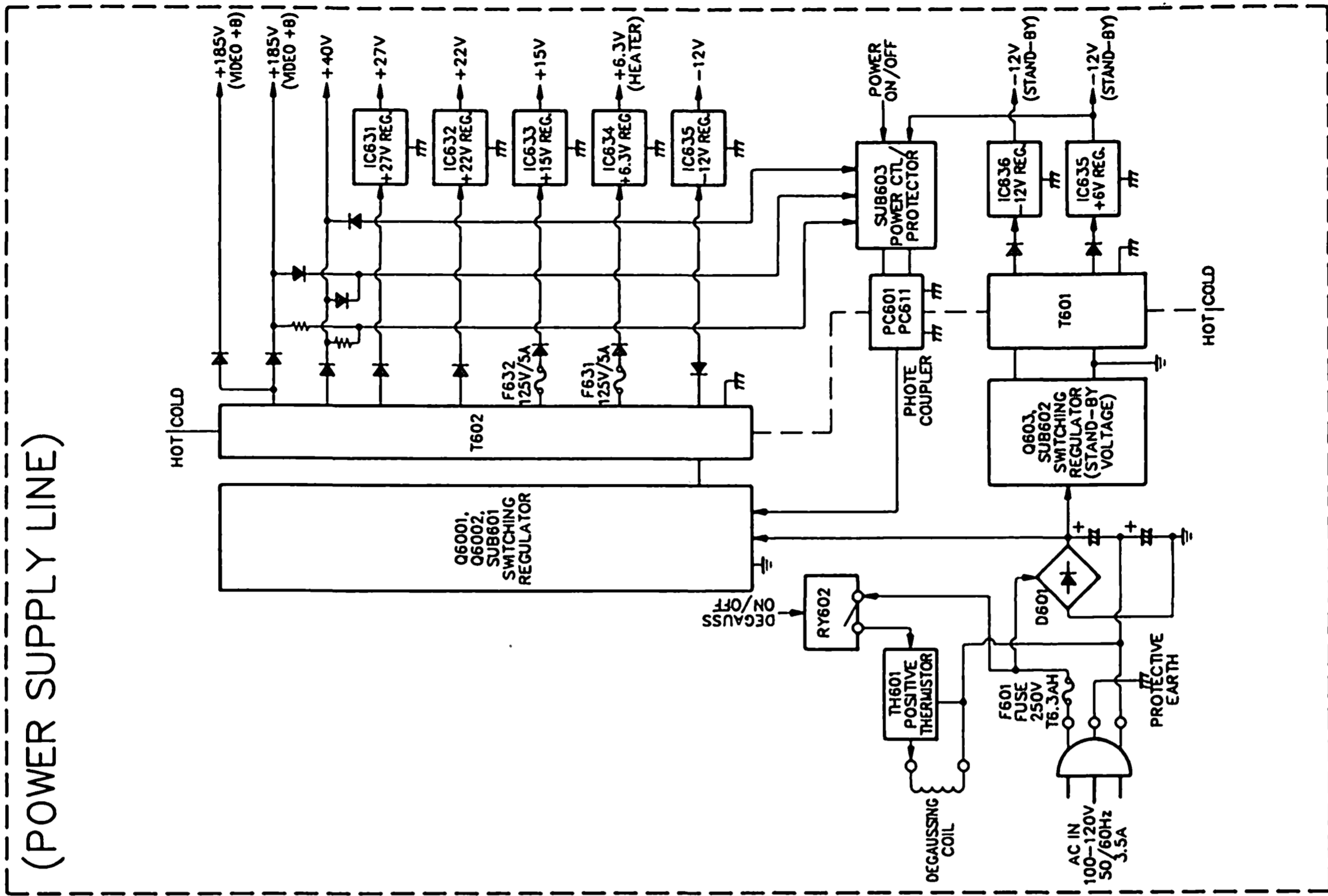

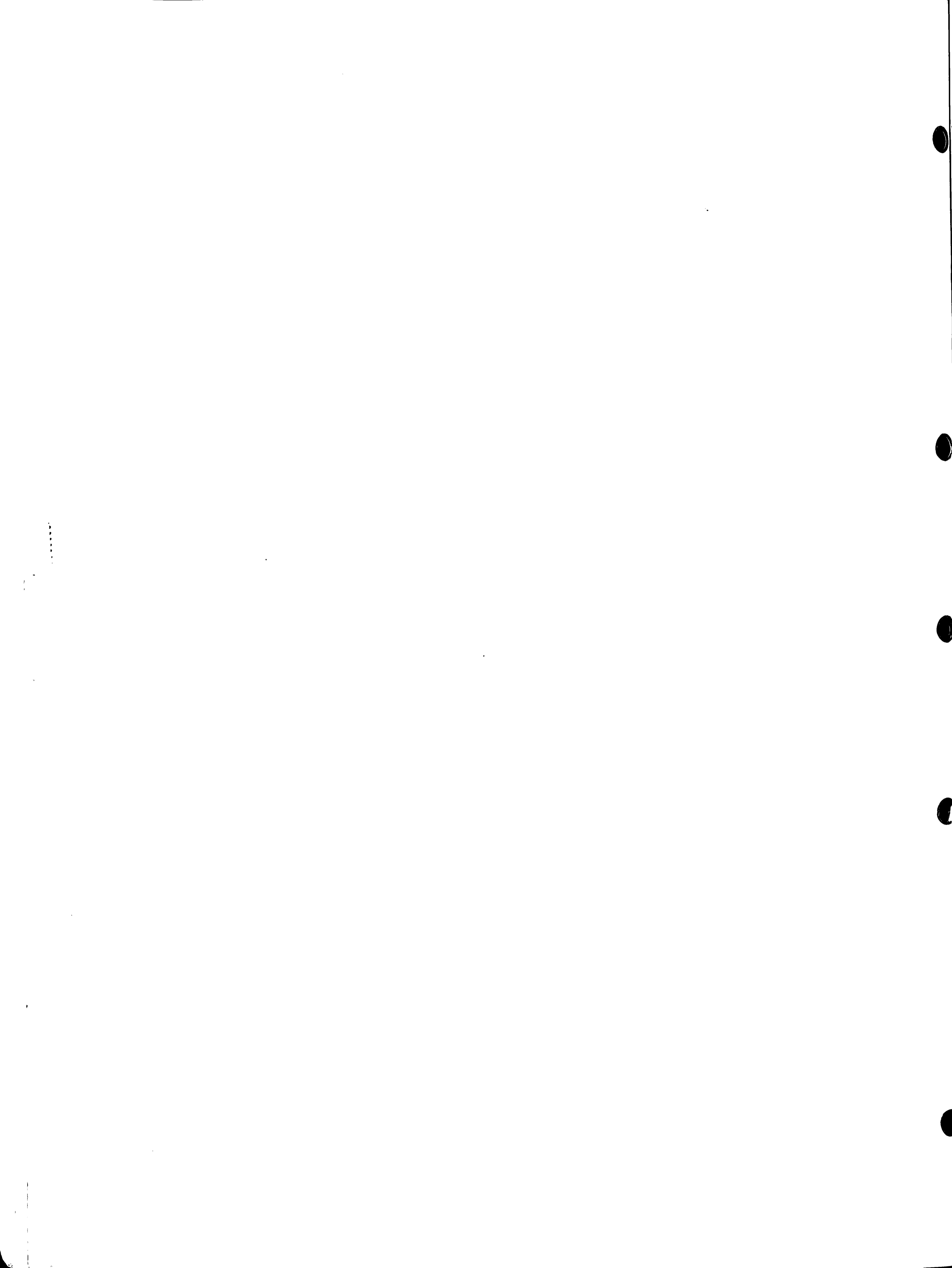

SCHEMATIC DIAGRAMS

1 2 3 4 5 6 7 8

A
B
C
D
E
F

RGB I/O PWB PWC-3835 SCHEMATIC DIAGRAM 1/2

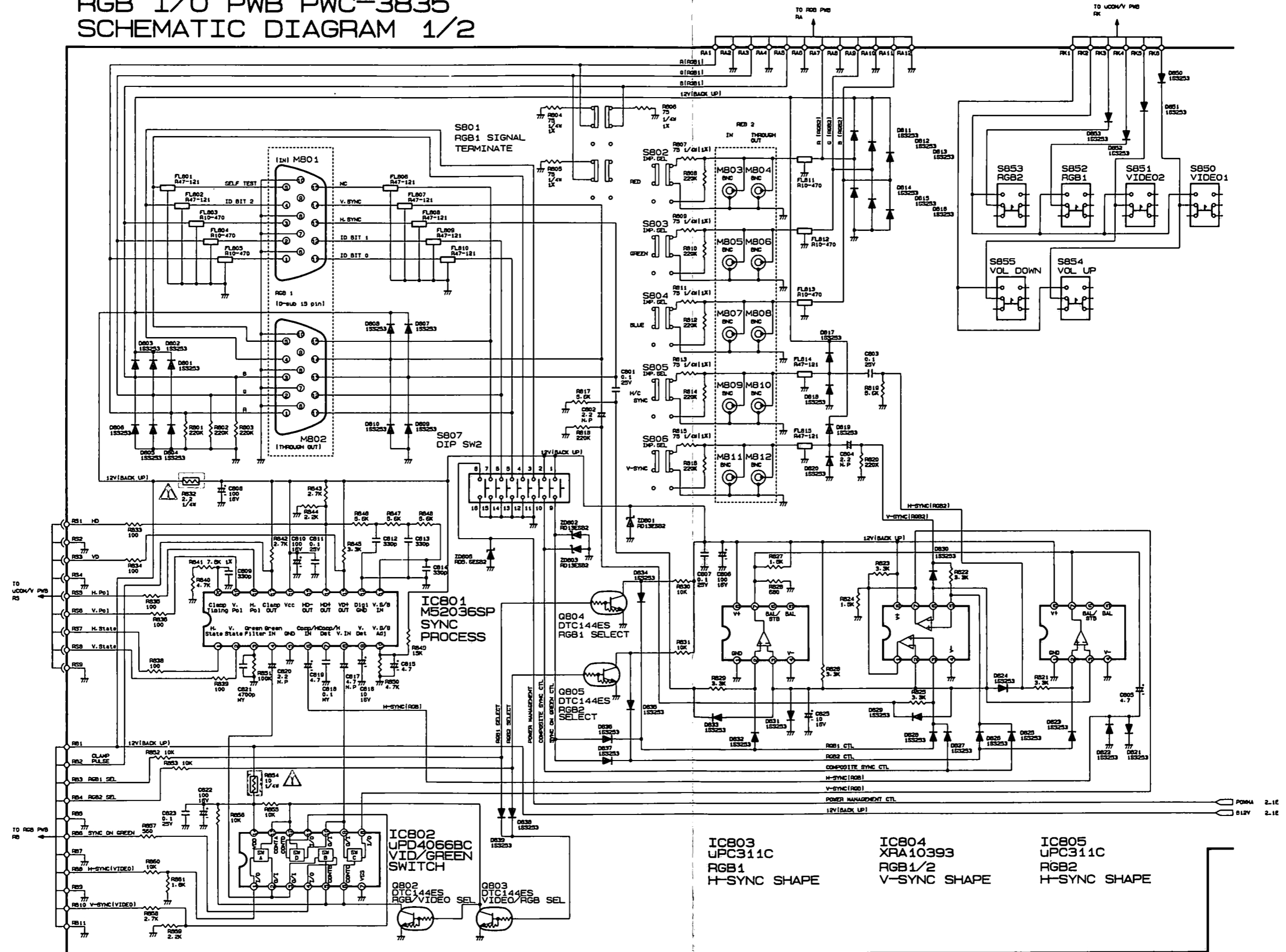

1

2

3

4

5

6

7

8

A

B

C

D

E

F

RGB I/O PWB PWC-3835 SCHEMATIC DIAGRAM 2/2

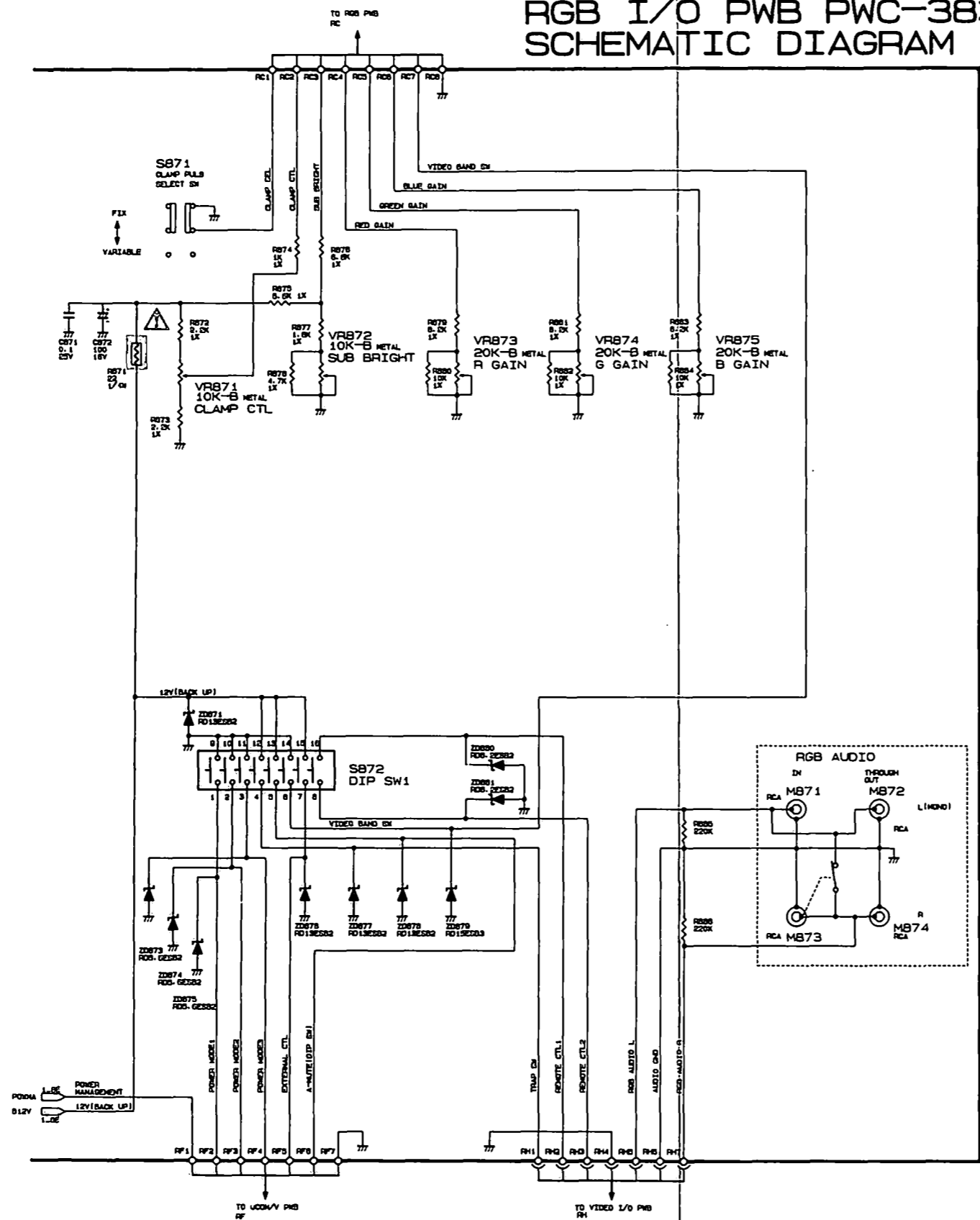

1 2 3 4 5 6 7 8

RGB PWB PWC-3836 SCHEMATIC DIAGRAM 2/2

A
B
C
D
E
F

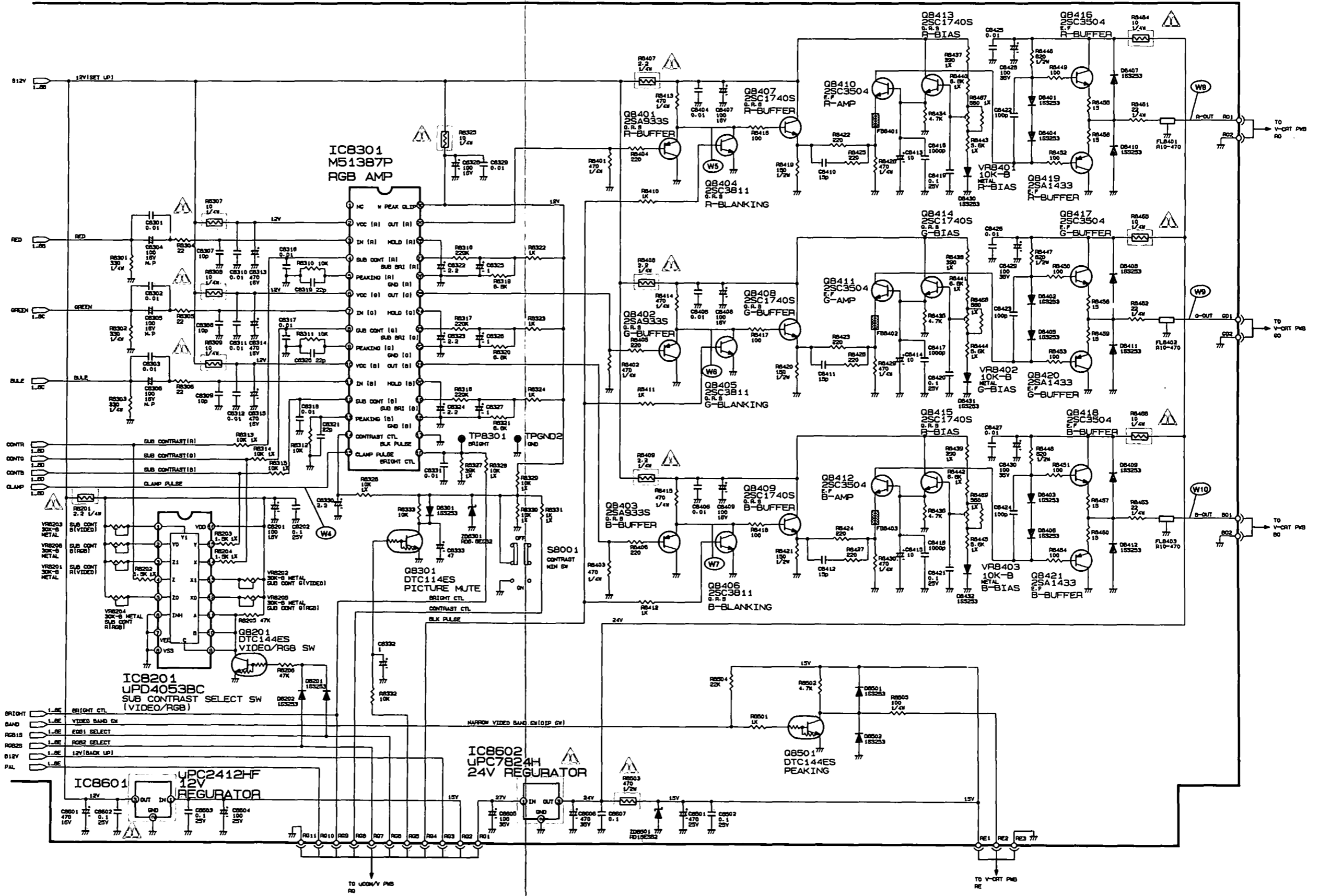

1 2 3 4 5 6 7 8

VIDEO I/O PWB PWC-3837 SCHEMATIC DIAGRAM

A
B
C
D
E
F

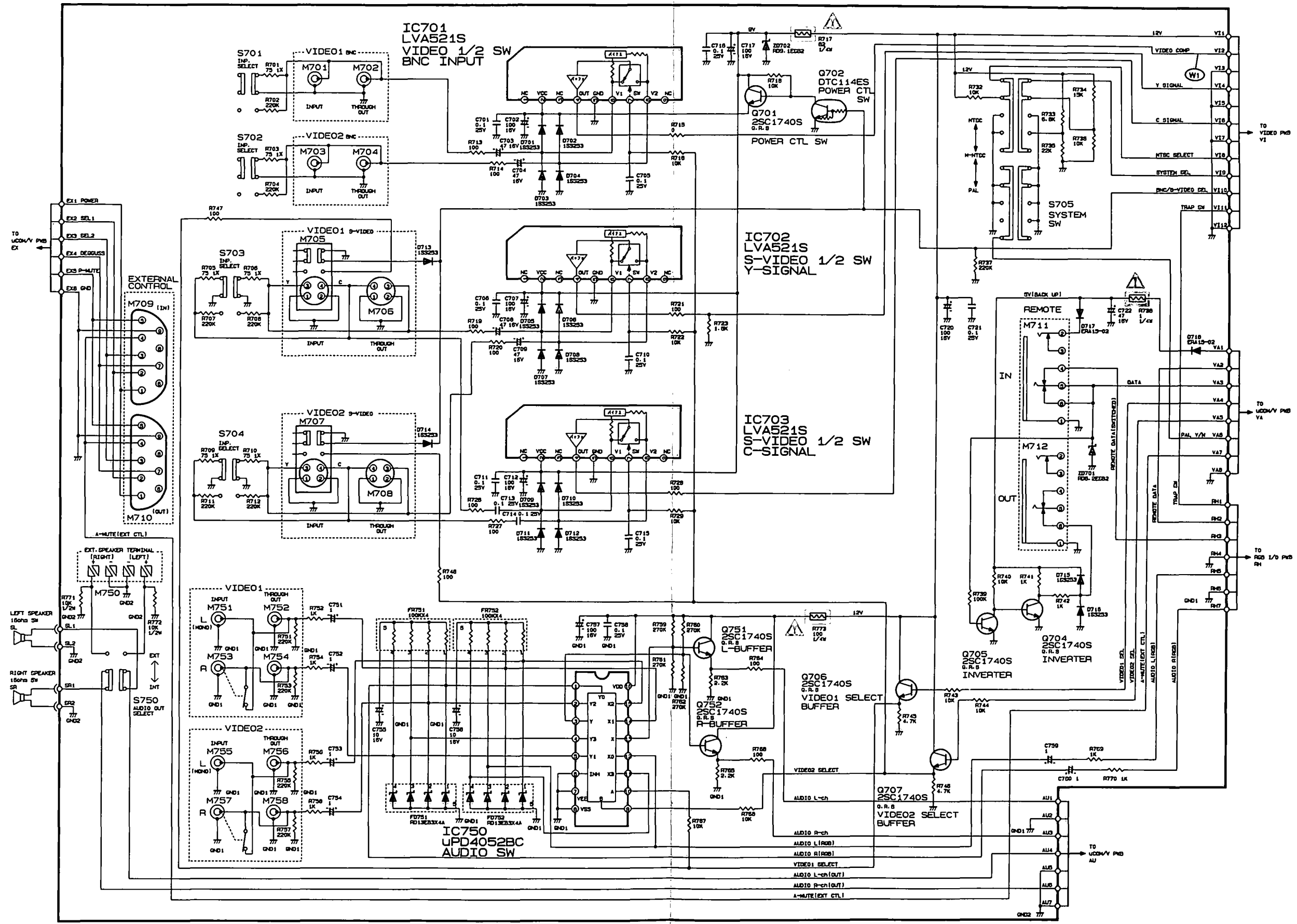

1 2 3 4 5 6 7 8

VIDEO PWB PWC-3838 SCHEMATIC DIAGRAM 2/2

A
B
C
D
E
F

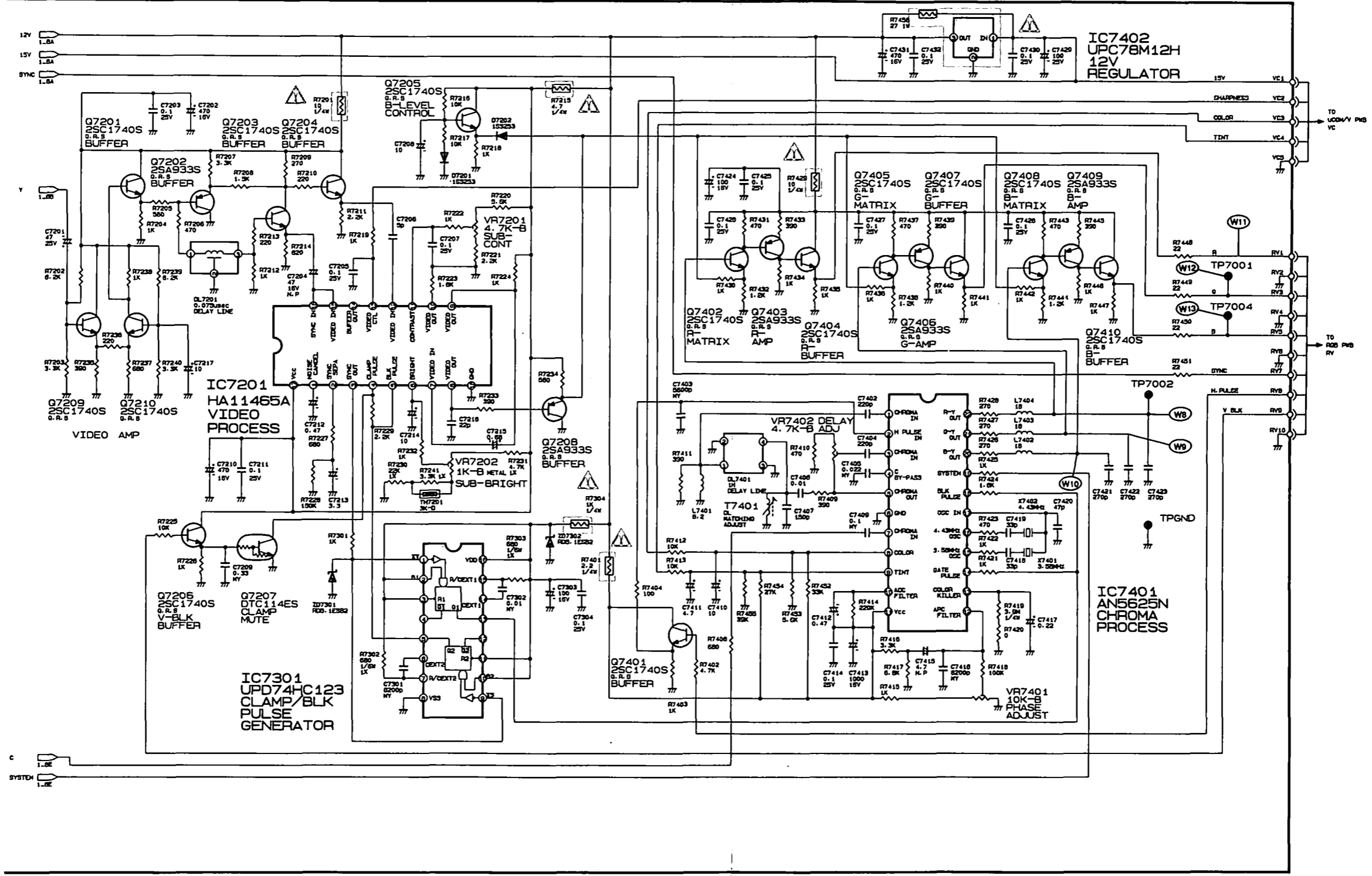

1 2 3 4 5 6

V-CRT PWB PWC-3834 SCHEMATIC DIAGRAM

A
B
C
D

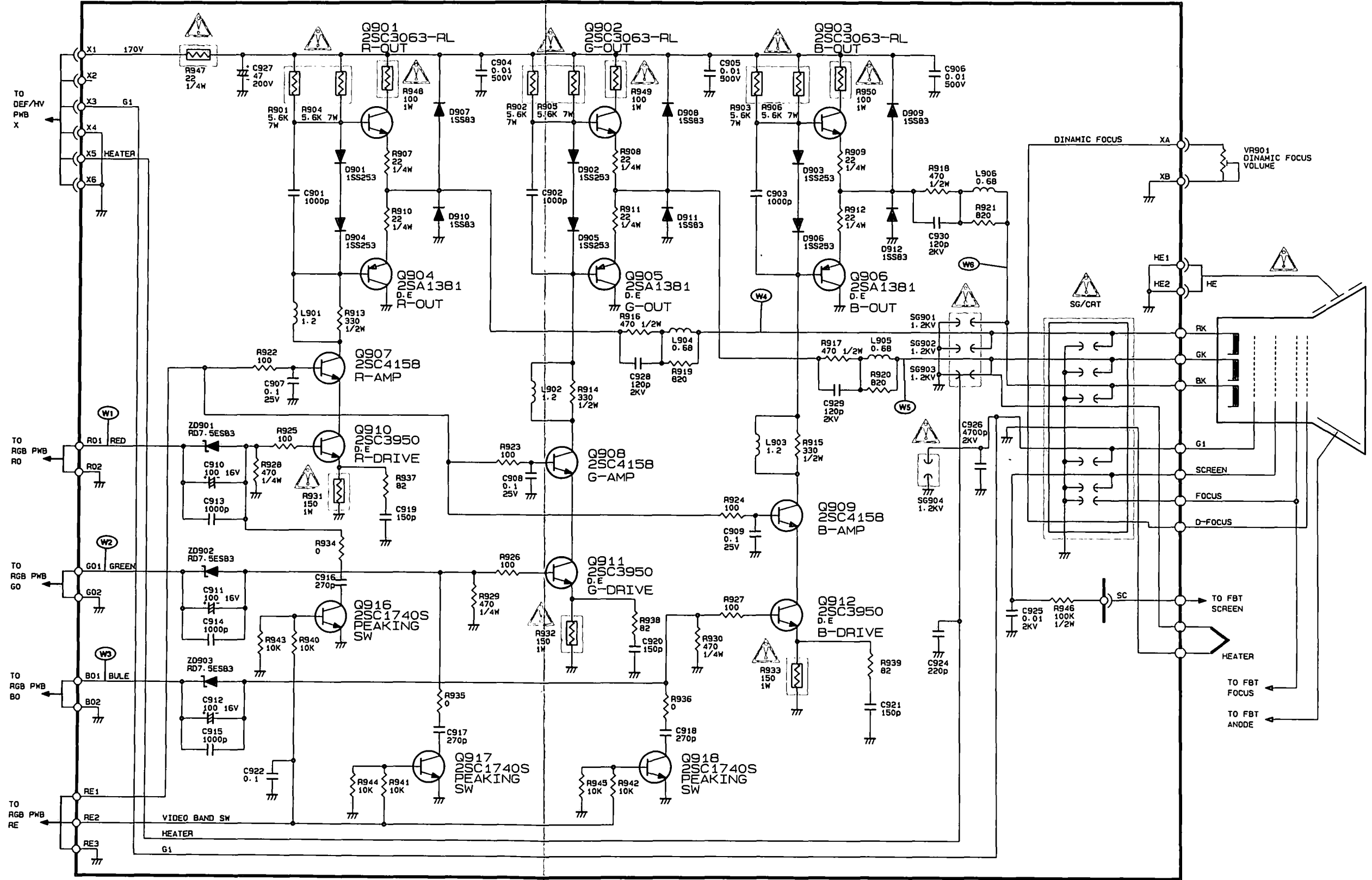

UCOM/V PWB PWC-3839 SCHEMATIC DIAGRAM 1/3

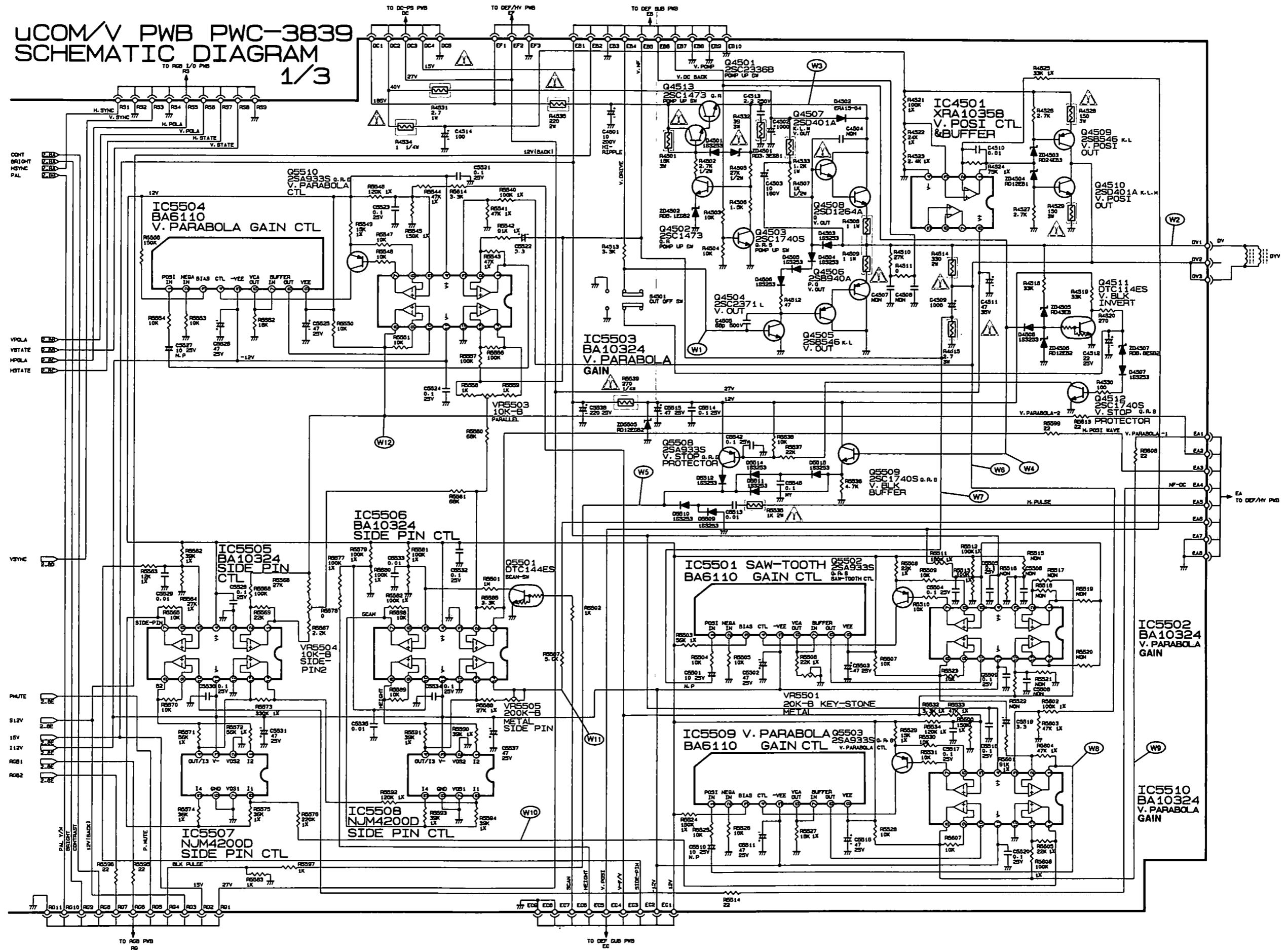

UCOM/V PWB PWC-3839 SCHEMATIC DIAGRAM 2/3

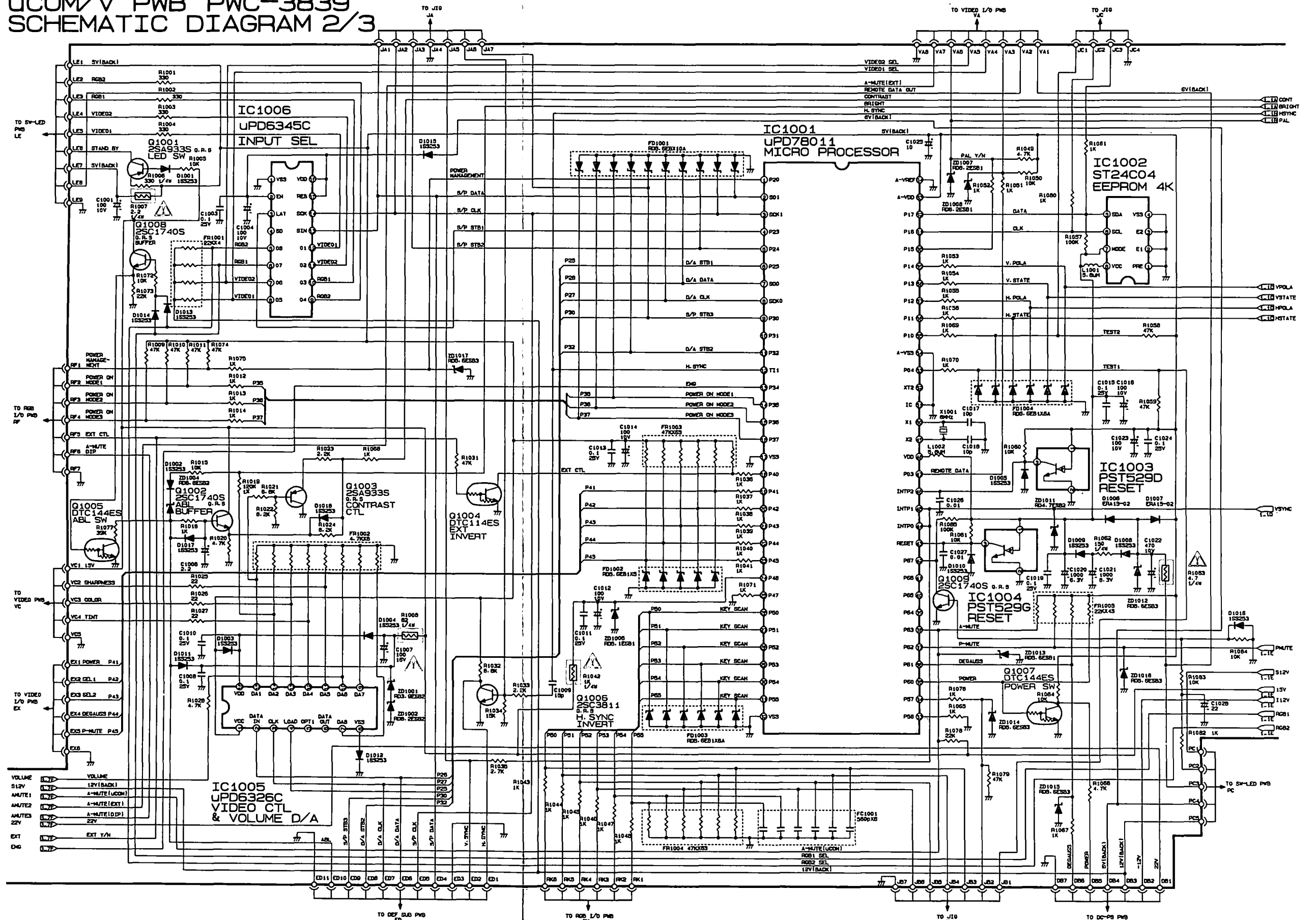

UCOM/V PWB PWC-3839 SCHEMATIC DIAGRAM 3/3

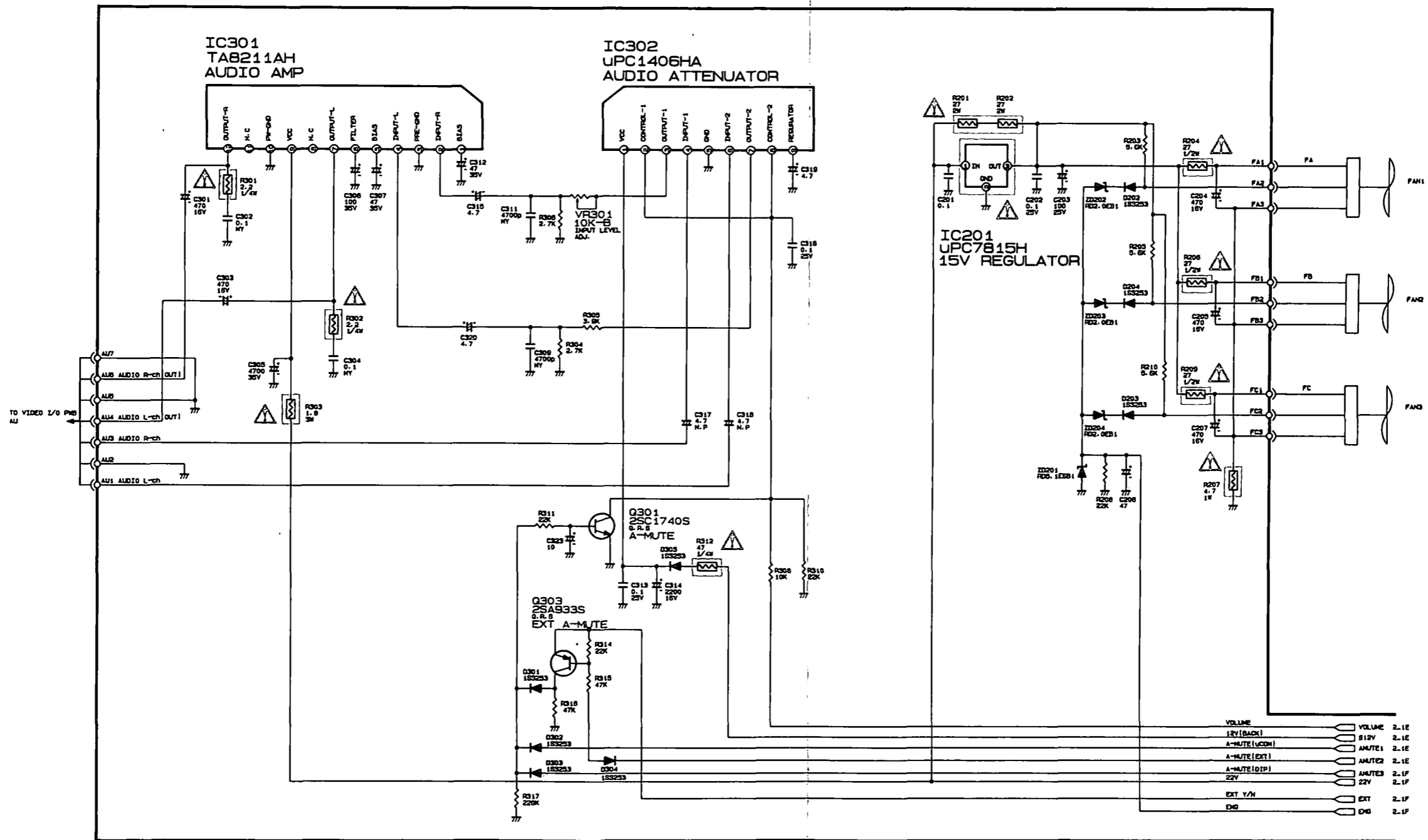

- VOLUME 2-1E
- 12V (BACK) 2-1E
- 512V 2-1E
- A-MUTE (UCOM) 2-1E
- A-MUTE (EXT) 2-1E
- A-MUTE (DIP) 2-1P
- 22V 2-1P
- EXT V/A 2-1P
- ENG 2-1P

DEF/HV PWB PWC-3846
SCHEMATIC DIAGRAM 2/2

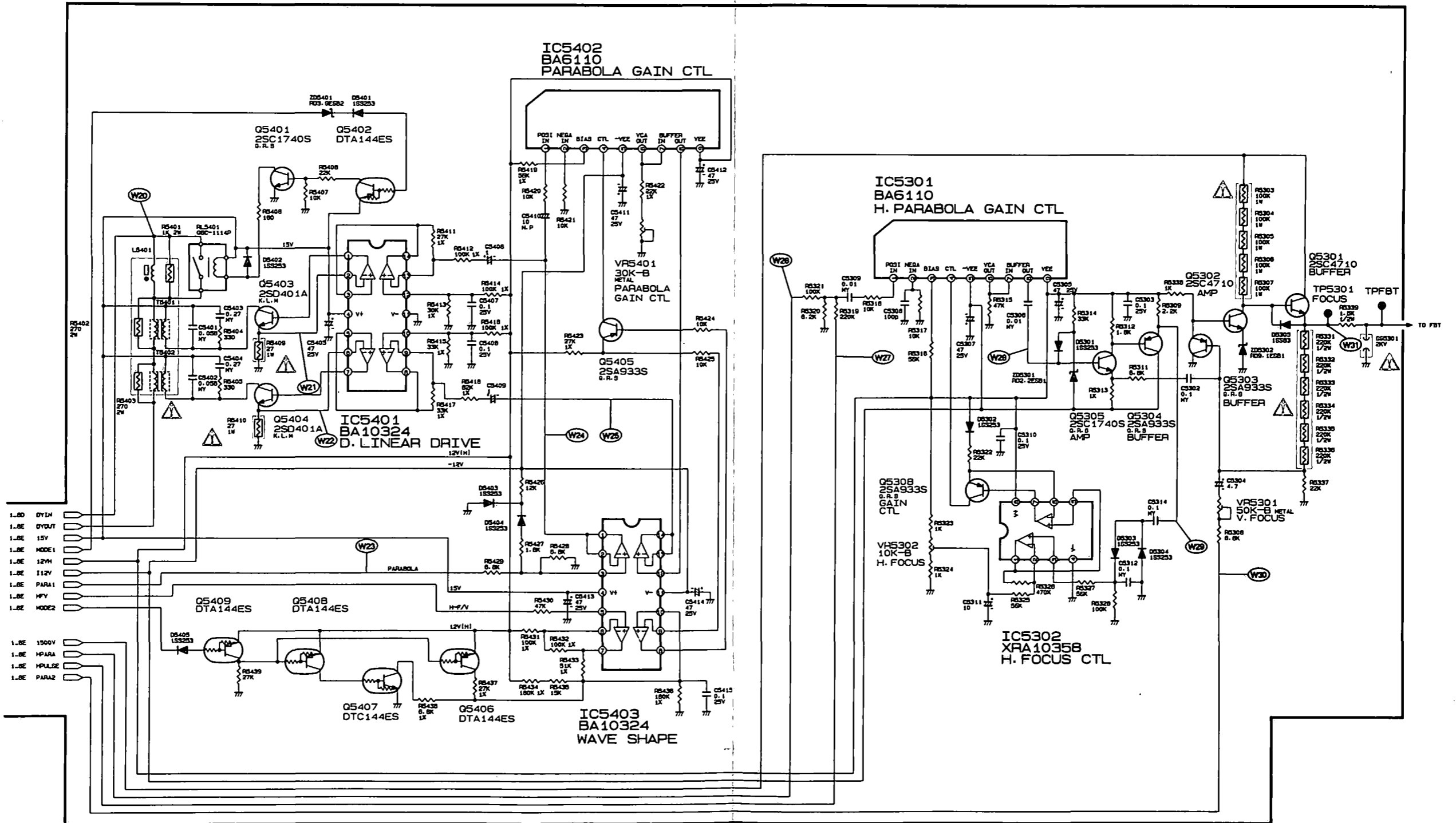

DEF SUB PWB PWC-3856A SCHEMATIC DIAGRAM 1/2

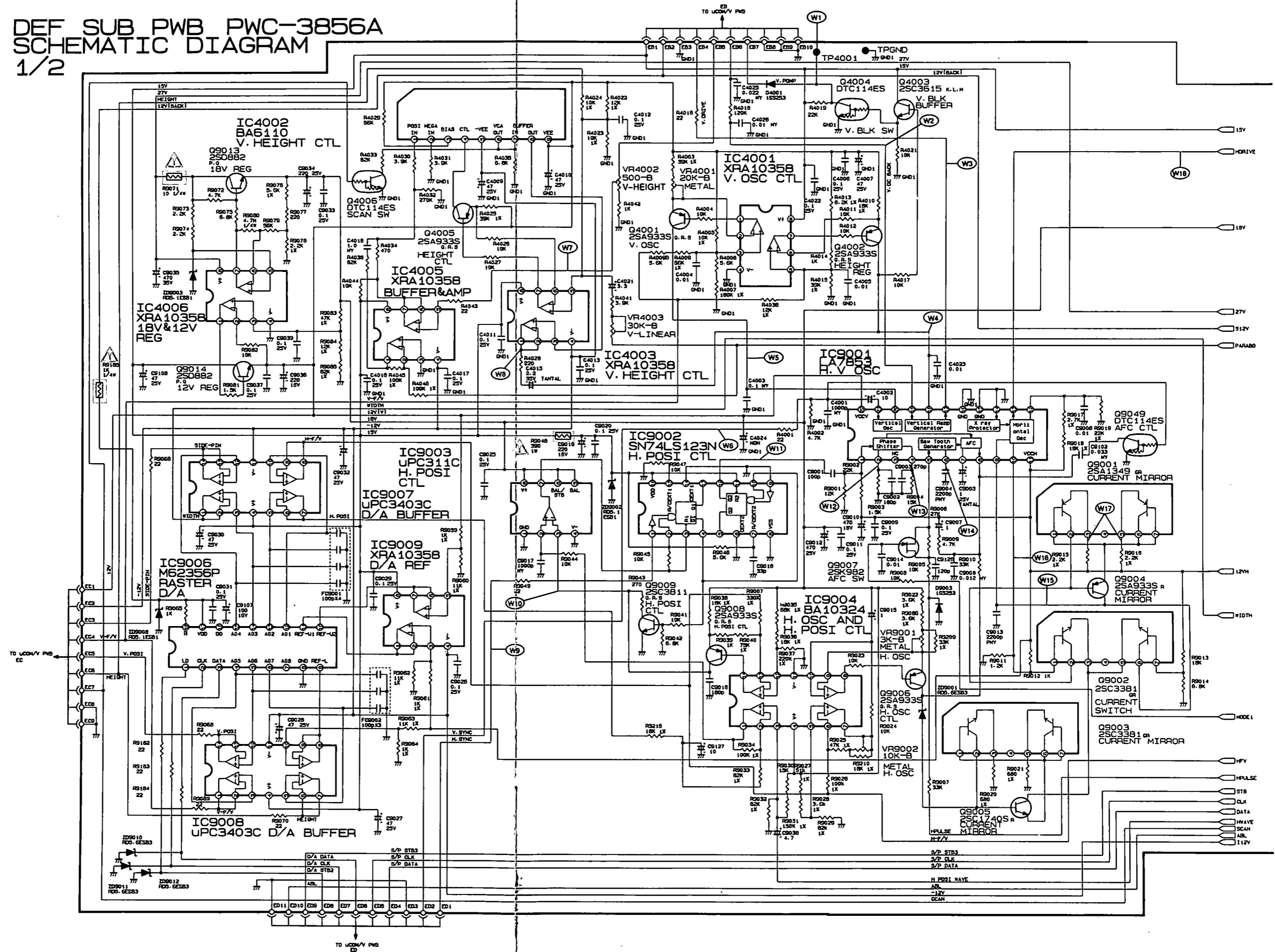

1 2 3 4 5 6 7 8
DEF SUB PWB 2/2
SCHEMATIC DIAGRAM

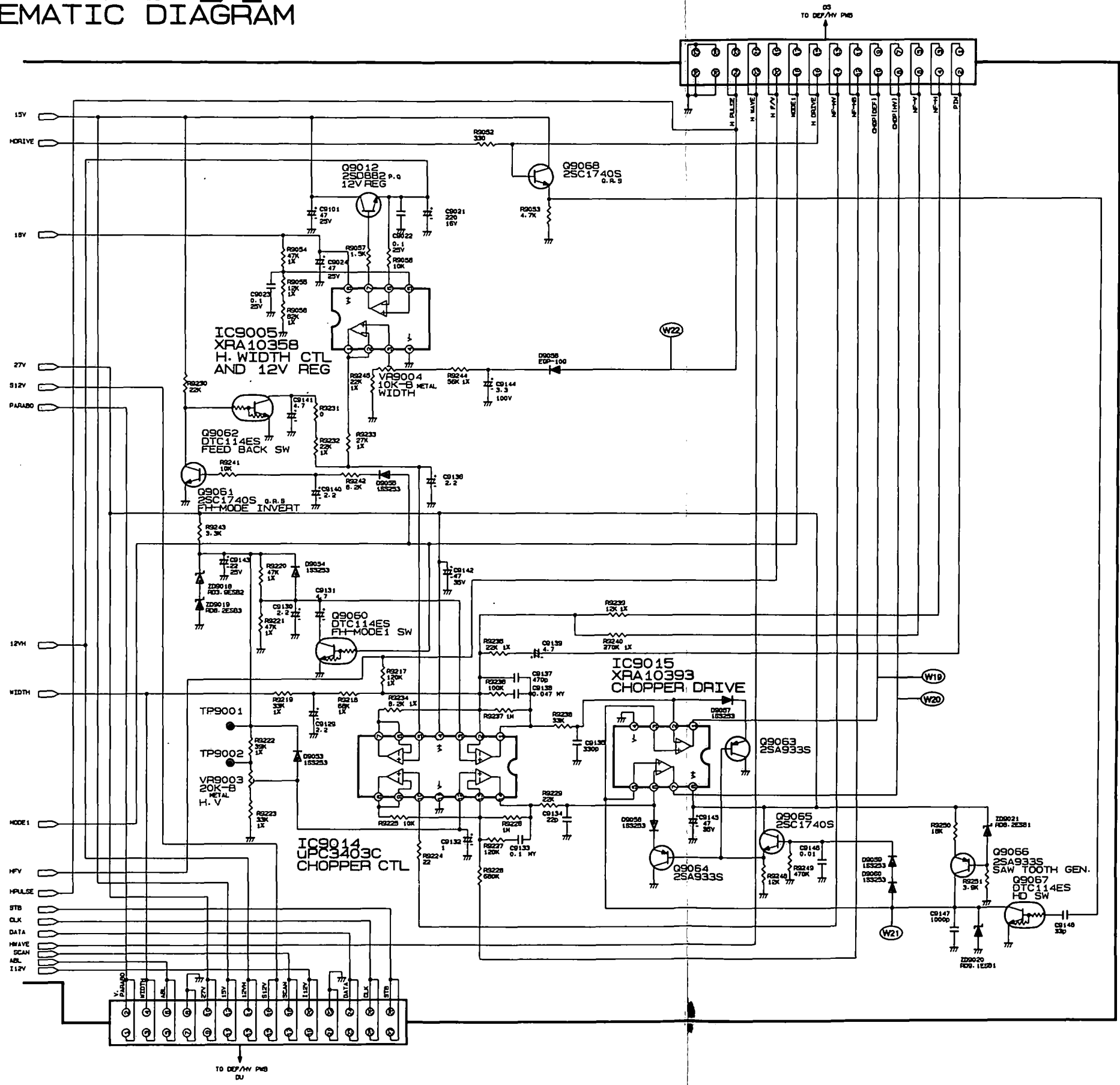

A

B

C

D

E

F

MAIN POWER SUPPLY PWB (PWC-3851A)

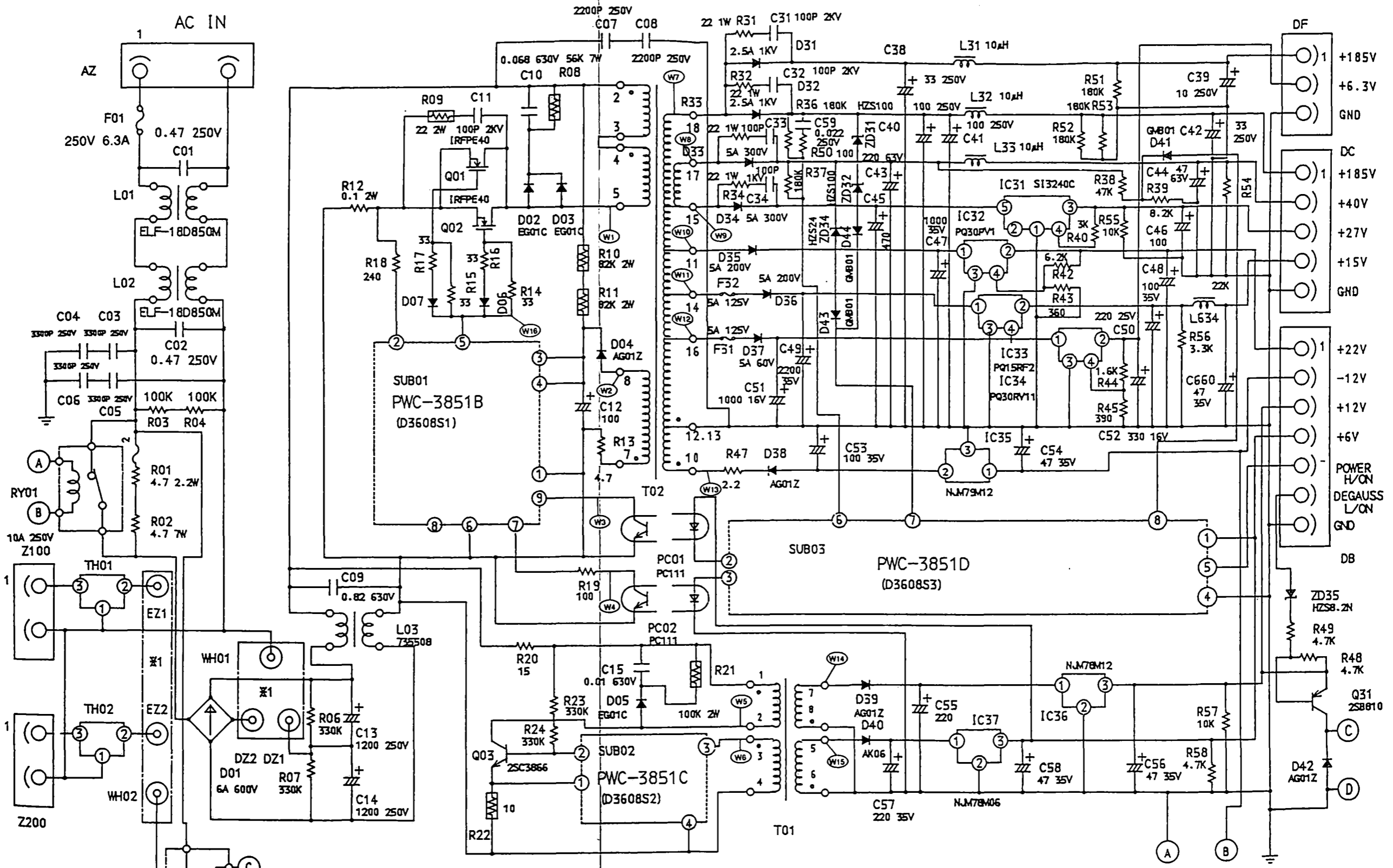

- ⊗1 100V-DZ1, EZ1/200V-DZ2, EZ2
- ⊗2 ALL SYMBOLS STAND FOR 6XX
- ⊗3 All capacitor are in μF
50V unless otherwise noted.
- ⊗4 All resistor are in ohm.
1/4W unless otherwise noted.

RY02
10A 250V

SUB POWER SUPPLY PWB (PWC- 3851B, C, D)

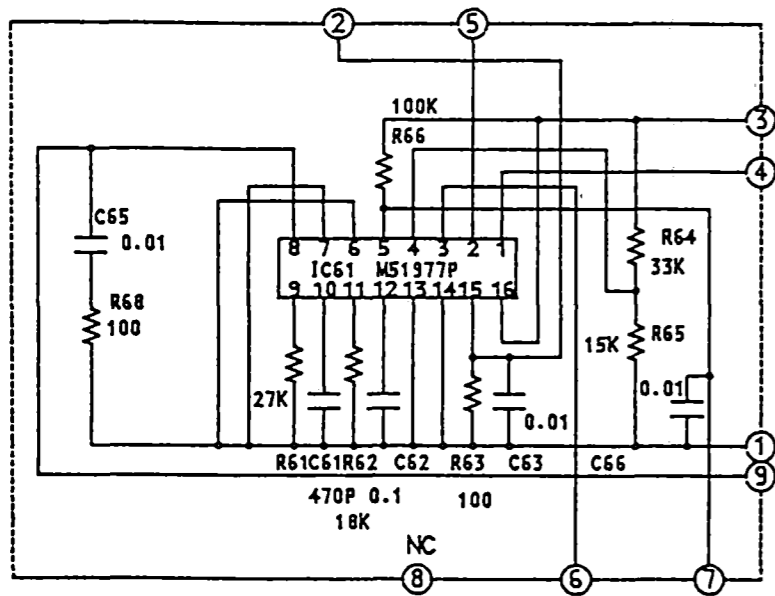

SUB601 (D3608S1)

PWC-3851B

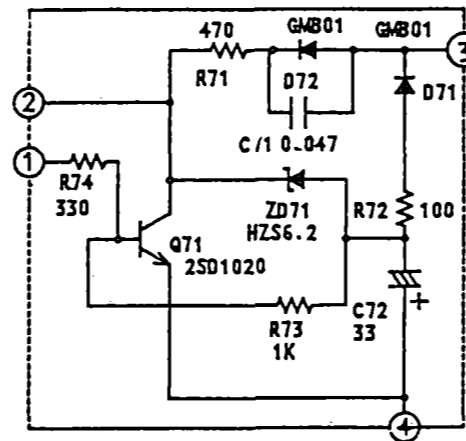

SUB602 (D3608S2)

PWC-3851C

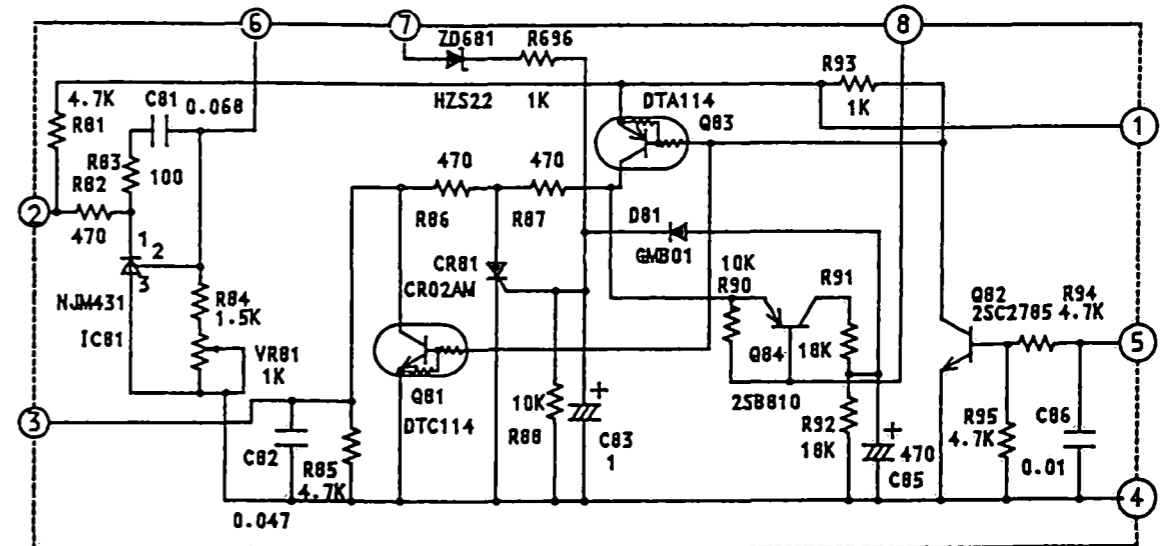

SUB603 (D3608S3)

PWC-3851D

H OUT PWB PWC-3856B SCHEMATIC DIAGRAM

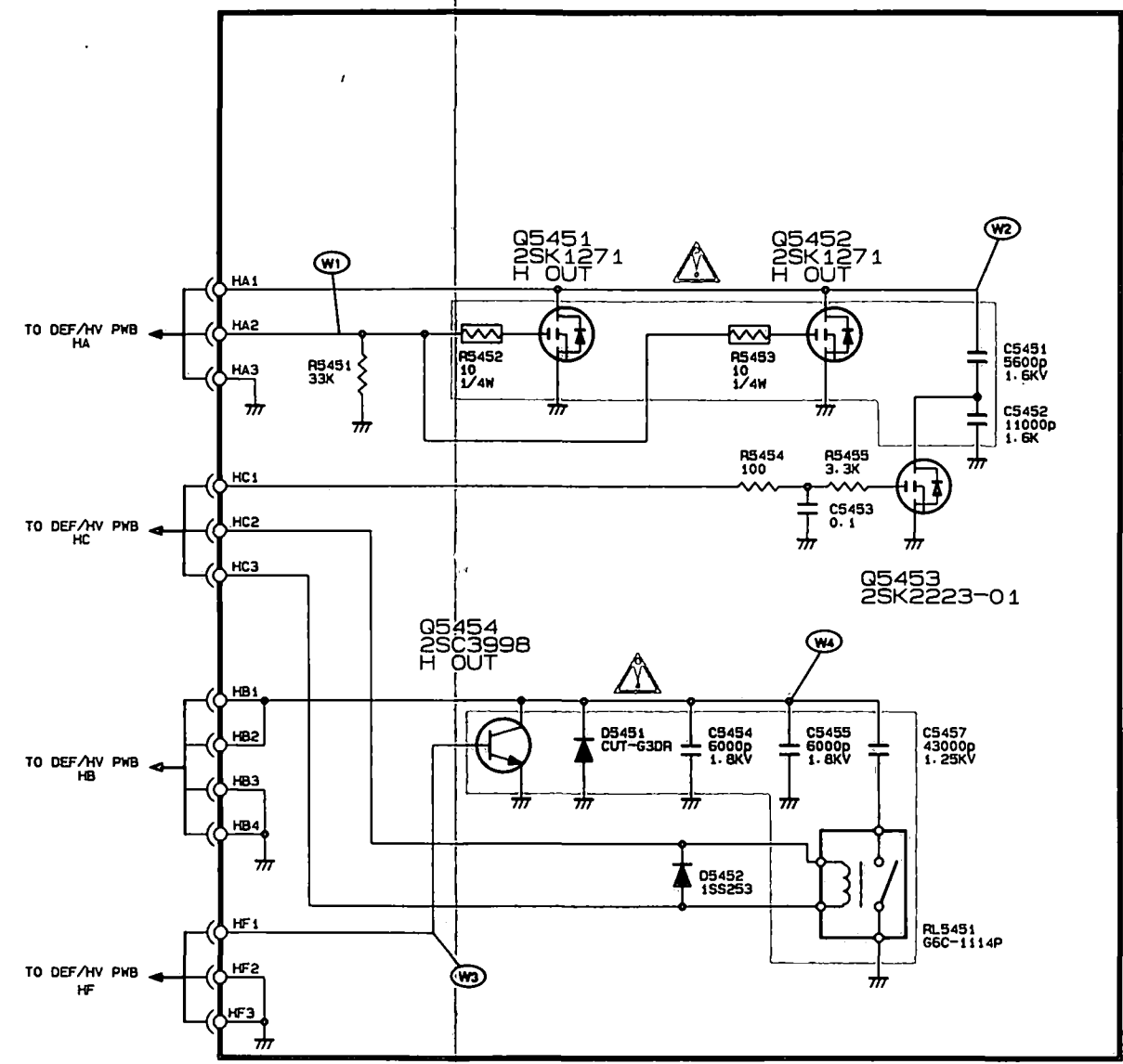

1 2 3 4 5 6

A

SW-LED PWB PWC-3838B SCHEMATIC DIAGRAM

B

C

D

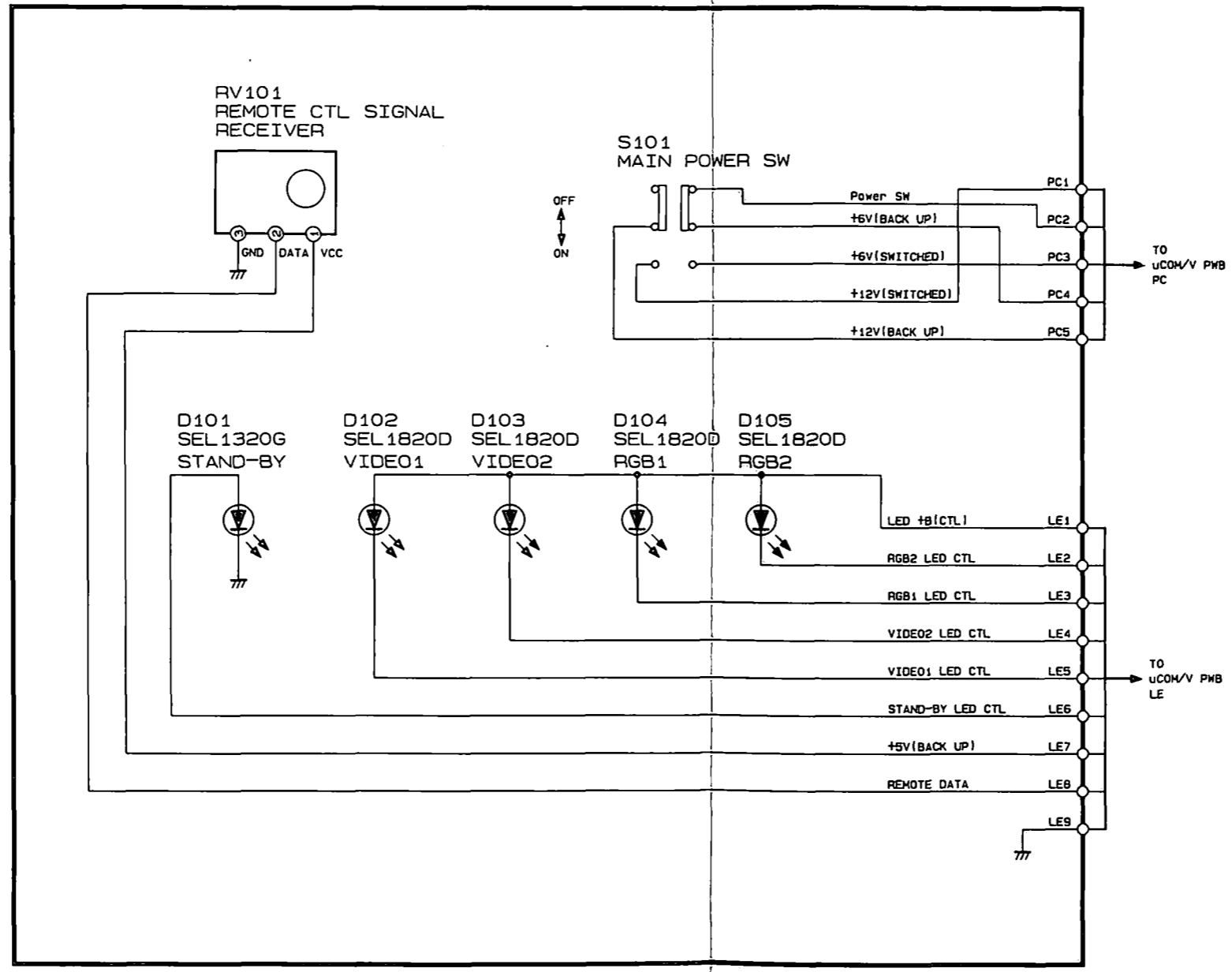

NEC

C&C for Human Potential

PRINTED IN JAPAN
630MI9402
01136981 (PG-2740)